

# installation and servicing

## mexico

Your Ideal installation and servicing guide

See reverse for **mexico** users guide

For details of document amendments, refer to page 3

## HE15, HE18, HE24, HE30, HE36

When replacing any part on this appliance, use only spare parts that you can be assured conform to the safety and performance specification that we require. Do not use reconditioned or copy parts that have not been clearly authorised by Ideal Boilers.

January 2008 UIN 201 787 A07

For the very latest copy of literature for specification purposes please visit our website [www.idealboilers.com](http://www.idealboilers.com) where you will be able to download the relevant information in pdf format.

**i** Ideal BOILERS  
The High Efficiency Pioneers



# DOCUMENT AMENDMENTS

Relevant Installation changes implemented in this book from Mod Level ..... A06 (Oct 06) to A07 (Jan 07)

---

- **Various Pages**  
Company name change.
- **Page 7, Optional Extra Kits**  
Addition of two new kits.
- **Page 9, Electrical Supply**  
Note for fan voltage.
- **Page 18, Frame 18 - Condensate Pipe Termination Configurations**  
Statement added with ref. to termination into a down pipe.
- **Page 18, Frame 18 - Condensate Pipe Termination Configurations**  
BS6798 recommends that a second trap and an air break are required where the siphon trap within the boiler is less than 75mm for configuration 3.
- **Page 29, Frame 38 - External Electrical Controls**  
Change to drawings re. position of “L1” and “L2”.
- **Page 30, Frame 40 - Initial Lighting**  
Display code “P” added to “The Display” paragraph.
- **Page 47, Frame 73 - L...E... or H... E... (Board Error)**  
Addition of new flowchart.
- **Page 48, Frame 74 - L...A... (Overheat Error)**  
Note added.
- **Page 49, Frame 78 - H...4... Dry Fire Thermistor, H9/L9 (Flue Gas Overheat)**  
Wording of “thermistor” changed to read “dry fire thermistor”.  
Note added.
- **Page 50, Short List of Parts**  
Part number change to PCB Primary Control.
- **Users Guide, Page 2 - Important Notes**  
2 new bullet points added.
- **Users Guide, Page 2 - Operation**  
Addition of display code “P”.

---

*Ideal Stelrad Group reserve the right to vary specification without notice*

---

# GENERAL

**Table 1 - General Data**

Boiler Size		HE15	HE18	HE24	HE30	HE36
Gas Supply Connection	in. BSP	Rc 1/2	Rc 1/2	Rc 1/2	Rc 1/2	Rc 1/2
Flow and Return Connections		22mm copper	22mm copper	22mm copper	22mm copper	22mm copper
MAXIMUM Static Water Head	m (ft.)	30.5 (100)	30.5 (100)	30.5 (100)	30.5 (100)	30.5 (100)
MINIMUM Static Water Head	m (ft.)	0.45 (1.5)	0.45 (1.5)	0.45 (1.5)	0.45 (1.5)	0.45 (1.5)
Electrical Supply		230V - 50Hz	230V - 50Hz	230V - 50Hz	230V - 50Hz	230V - 50Hz
Power Consumption		38W	38W	38W	42W	42W
Fuse Rating		External : 3A internal T3.15A L250V				
Water Content	litre (gal.)	2.0 (0.44)	2.0 (0.44)	2.0 (0.44)	4.7 (1.0)	4.7 (1.0)
Packaged Weight	kg. (lb.)	54 (119)	54 (119)	54 (119)	68 (150)	68 (150)
Maximum Inst Weight	kg. (lb.)	47 (104)	47 (104)	47 (104)	67 (148)	67 (148)
Boiler Size	Height	mm (in.)	850 (33.5)	850 (33.5)	850 (33.5)	850 (33.5)
	Width	mm (in.)	450 (17.7)	450 (17.7)	450 (17.7)	450 (17.7)
	Depth	mm (in.)	530 (20.9)	530 (20.9)	530 (20.9)	530 (20.9)
Gas Type		I2H-G20	I2H-G20	I2H-G20	I2H-G20	I2H-G20
Gas Supply Pressure		20mb	20mb	20mb	20mb	20mb
Flue duct diameter	mm (in.)	100 (4)	100 (4)	100 (4)	100 (4)	100 (4)
Flue horizontal duct length (max)	m	6	6	6	3	3

**Table 2 - Performance Data**

Boiler Size		HE15 max	HE18 max	HE24 max	HE30 max	HE36 max	HE15-24 min	HE30-36 min
Input 'Q'	Nett CV kW (Btu/h)	15.1 (51,500)	18.7 (63,800)	24.4 (83,300)	30.7 (104,700)	37.5 (128,000)	9.1 (31,000)	10.6 (36,200)
	Gross CV kW (Btu/h)	16.8 (57,200)	20.7 (70,800)	27.1 (92,500)	34.0 (116,000)	41.6 (142,000)	10.1 (34,400)	11.8 (40,300)
	Gas Consumption l/s (cu.ft/h)	0.43 (54.7)	0.53 (68.0)	0.70 (89.7)	0.88 (111.9)	1.07 (136.0)	0.26 (33.3)	0.30 (38.4)
Output 'P'	70°C Mean Water temp. kW (Btu/h)	14.6 (50,000)	18.2 (62,300)	23.4 (80,000)	30.1 (102,700)	37.0 (126,200)	8.8 (30,000)	10.6 (36,200)
	40°C Mean Water temp. kW (Btu/h)	15.5 (53,000)	19.2 (65,700)	25.1 (85,700)	32.8 (111,800)	39.8 (135,800)	9.6 (32,800)	11.4 (38,900)
Seasonal efficiency (SEDBUK) *	Band A	[90.4]%	[90.3]%	[90.2]%	[90.4]%	[90.7]%	-	-
NOx classification		Class 5						

\* The value is used in the UK Government's Standard Assessment Procedure (SAP) for energy rating of dwellings. The test data from which it has been calculated have been certified by a notified body.

**Note.**

Gas consumption is calculated using a calorific value of 38.7 MJ/m<sup>3</sup> (1038 Btu/ft<sup>3</sup>) gross or 34.9 MJ/m<sup>3</sup> (935 Btu/ft<sup>3</sup>) nett. To obtain the gas consumption at a different calorific value:-

- a. For l/s - divide the gross heat input (kW) by the gross C.V. of the gas (MJ/m<sup>3</sup>)
- b. For ft<sup>3</sup>/h - divide the gross heat input (Btu/h) by the gross C.V. of the gas (Btu/ft<sup>3</sup>)

**Key to symbols**

**GB** = United Kingdom **IE** = Ireland (Countries of destination)

**PMS** = Maximum operating pressure of water

**C<sub>13</sub>C<sub>33</sub>** = A room sealed appliance designed for connection via ducts to a horizontal or vertical terminal which admits fresh air to the burner and discharges the products of combustion to the outside through orifices which, in this case, are concentric. The fan is up stream of the combustion chamber.

**I<sub>2H</sub>** = An appliance designed for use on 2nd Family gas, Group H only.

**CAUTION. To avoid the possibility of injury during the installation, servicing or cleaning of this appliance, care should be taken when handling edges of sheet steel components.**

## GENERAL

# mexico HE

Natural Gas only

Boiler size	G.C. Appliance No. (Benchmark No.)	PI No.
HE15	41-429-39	0063 BQ 3906
HE18	41-429-65	0063 BQ 3906
HE24	41-429-98	0063 BQ 3906
HE30	41-429-99	0063 BQ 3906
HE36	41-415-20	0063 BQ 3906

Destination Countries: GB, IE

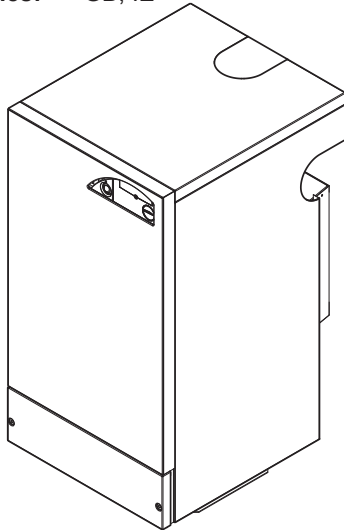

## CONTENTS

Air Supply .....	9
Benchmark Commissioning Checklist .....	54
Boiler Clearances .....	6
Boiler Exploded Diagram .....	14
Electrical Connections .....	27
Electrical Supply .....	9
Electrical Systems Diagrams .....	29
Extension Ducts - Fitting .....	22
Fault Finding .....	45-49
Flow Wiring Diagram .....	28
Flue Fitting .....	19-26
Flue Installation Requirements .....	8
Gas Safety Regulations .....	7
Gas Supply .....	8
Initial Lighting .....	30
Installation .....	14-31
Mandatory Requirements .....	7
Safe Handling .....	7
Servicing .....	32-44
Short List of Parts .....	50
Terminal Guards .....	8
Thermostatic Radiator valves .....	9
Water and Systems .....	10-13
Water Connections .....	6,17
Water Treatment .....	13
Wiring Diagrams .....	27-29

For GB, to comply with Building Regulations Part L1 (Part J in Scotland) the boiler should be fitted in accordance with the manufacturer's instructions. Self-certification that the boiler has been installed to comply with Building Regulations can be demonstrated by completing and signing the Benchmark Commissioning Checklist.

### BENCHMARK COMMISSIONING CHECKLIST DETAILS

Boiler	Page	Page	
Make and model .....	5	Burner operating pressure .....	measure and record
Appliance serial no. on data badge .....	14	Central heating flow temp. ....	measure and record
SEDBUK No. % .....	4	Central heating return temp. ...	measure and record
<b>Controls</b>		<b>For combination boilers only</b>	
Time and temperature control to heating .....	29	Scale reducer .....	n/a
Time and temperature control to hot water .....	29	<i>Hot water mode</i>	
Heating zone valves .....	n/a	Heat input .....	n/a
TRV's .....	9	Max. operating burner pressure .....	n/a
Auto bypass .....	9	Max. operating water pressure .....	n/a
Boiler interlock .....	9	Cold water inlet temp .....	n/a
<b>For all boilers</b>		Hot water outlet temp. ....	n/a
Flushing to BS.7593 .....	13	Water flow rate at max. setting .....	n/a
Inhibitor .....	13	<b>For condensing boilers only</b>	
<i>Central heating mode</i>		Condensate drain .....	17
Heat input .....	to be calculated	<b>For all boilers: complete, sign &amp; hand over to customer</b>	

For assistance see Technical Helpline on the back page

**NOTE TO THE INSTALLER: COMPLETE THE BENCHMARK COMMISSIONING CHECKLIST AND LEAVE THESE INSTRUCTIONS WITH APPLIANCE**



# GENERAL

## 1 BOILER SERVICE CONNECTIONS

1. This appliance is NOT suitable for use in a direct hot water system.
2. If the boiler is to be used on a sealed system an **Overheat Thermostat** is fitted as standard.

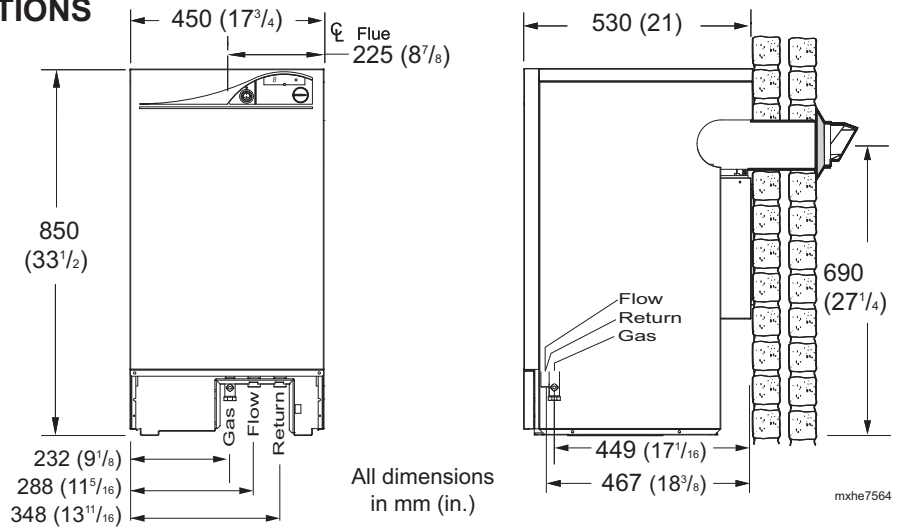

## 2 FLOOR MOUNTING AND BOILER CLEARANCES

*Flammable materials must not be placed in close proximity to the appliance. Materials giving off flammable vapours must not be stored in the same room as the appliance.*

### Floor mounting

1. The floor must be flat, level and of suitable load bearing capacity.
2. The back of the boiler may be fitted up to the wall.

### Boiler clearances

The minimum overall dimensions of the space in which the boiler is to operate and to facilitate servicing are as shown

Additional space may be required for installation, depending upon site conditions.

In addition a MINIMUM clearance of 450 mm (17<sup>3</sup>/<sub>4</sub>" ) MUST be available at the front of the boiler, for servicing.

Minimum front clearance when built behind a concealing panel is 5mm (1/<sub>4</sub>").

Boiler Model	Flue Length	Overall Space Dim.		
		Depth	Height	Width
HE15	6 m	530	870	460
HE18	6 m	530	870	460
HE24	6 m	530	870	460
HE30	3 m	530	870	460
HE36	3 m	530	870	460

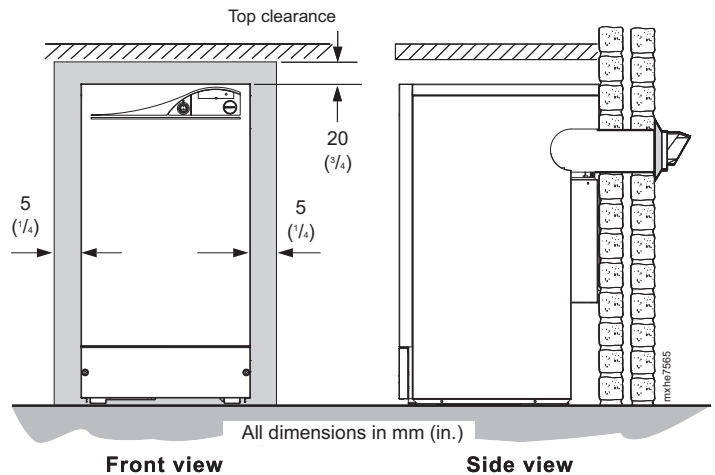

## INTRODUCTION

The **mexico HE** range of boilers are fully automatically controlled, floor standing, low water content, balanced flue, fanned, condensing gas boilers. They have full modulating central heating outputs of :

**HE15** 8.8 kW (30,000 Btu/h) to 14.6 kW (50,000 Btu/h).

**HE18** 8.8 kW (30,000 Btu/h) to 18.2 kW (62,300 Btu/h).

**HE24** 8.8 kW (30,000 Btu/h) to 23.4 kW (80,000 Btu/h).

**HE30** 10.6 kW (36,200 Btu/h) to 30.1 kW (102,700 Btu/h).

**HE36** 10.6 kW (36,200 Btu/h) to 37.0 kW (126,200 Btu/h).

Due to the very high efficiency of the boiler a plume of water vapour will form at the flue terminal during operation depending on external conditions.

The boiler casing is of white painted mild steel with the user controls capable of being mounted remotely from the boiler, if the option is required.

The heat exchanger is of cast aluminium.

Artificially softened water must NOT be used.

A pre-piping frame is provided to allow system and gas connection to be made prior to boiler installation.

### Note.

*These boilers cannot be used on systems which include gravity circulation.*

The boilers are suitable for connection to fully pumped, open vented or sealed water systems. Adequate arrangements for completely draining the system by provision of drain cocks MUST be provided in the installation pipework.

# GENERAL

## OPERATION

When there is a demand for heat, the heating system is supplied at the selected temperature of between 30°C and 82°C.

The boiler features a comprehensive diagnostic system which gives detailed information on the boiler status when operating, and performance of key components to aid commissioning and fault finding.

## SAFE HANDLING

This boiler may require 2 or more operatives to move it to its installation site, remove it from its packaging base and during movement into its installation location. Manoeuvring the boiler may include the use of a sack truck and involve lifting, pushing and pulling.

Caution should be exercised during these operations.

Operatives should be knowledgeable in handling techniques when performing these tasks and the following precautions should be considered:

- Grip the boiler at the base.
- Be physically capable.
- Use PPE as appropriate, e.g. gloves, safety footwear.

During all manoeuvres and handling actions, every attempt should be made to ensure the following unless unavoidable and/or the weight is light.

- Keep back straight.
- Avoid twisting at the waist.
- Avoid upper body/top heavy bending.
- Always grip with the palm of the hand.
- Use designated hand holds.
- Keep load as close to the body as possible.
- Always use assistance if required.

## OPTIONAL EXTRA KITS

### FLUING:

- **Flue Extension Ducts.** (1000mm long)  
HE15, 18 & 24 -up to 6m  
HE30, & 36 - up to 3m
- **90° Elbow Kit** (60/100 dia maximum no. per installation)  
HE15, 18 & 24 -up to 4 elbows  
HE30, & 36 - up to 2 elbows
- **45° Elbow Kit** (60/100 dia maximum no. per installation)  
HE15, 18 & 24 -up to 4 elbows  
HE30, & 36 - up to 2 elbows
- **Roof Flue Kit** (60/100)  
HE15, 18 & 24 -up to a maximum of 8m  
HE30, & 36 -up to a maximum of 5m
- **Pitched Roof Tile** (for roof flue kit)
- **Flat Roof Tile** (for roof flue kit)
- **Vertical Flue Adaptor**
- **Vertical Outlet Flue Kit with Elbow** (60/100)  
HE15, 18 & 24 - to a maximum length of 6m  
HE30, & 36 - to a maximum length of 3m
- **Flue Finishing Kit**
- **High Level Flue Outlet Kit**
- **Flue Deflector Kit**

### OTHER OPTIONAL KITS:

- **Remote User Control Kit**
- **Condensate Pump Kit**
- **Concealment Panel Kit**
- **RS Boiler Terminal Wall Plate Kit**

## SAFETY

### Current Gas Safety (Installation and Use) Regulations or rules in force.

The appliance is suitable only for installation in GB and IE and should be installed in accordance with the rules in force.

In GB, the installation must be carried out by a CORGI Registered Installer. It must be carried out in accordance with the relevant requirements of the:

- Gas Safety (Installation and Use) Regulations
- The appropriate Building Regulations either The Building Regulations, The Building Regulations (Scotland), Building Regulations (northern Ireland).
- The Water Fittings Regulations or Water bye-laws in Scotland.
- The Current I.E.E. Wiring Regulations.

Where no specific instructions are given, reference should be made to the relevant British Standard Code of Practice.

In IE, the installation must be carried out by a Competent Person and installed in accordance with the current edition of I.S.813 "Domestic Gas Installations", the current Building Regulations and reference should be made to the current ETCI rules for electrical installation.

Detailed recommendations are contained in the following British Standard Codes of Practice:

- BS. 5440:1** Flues (for gas appliances of rated input not exceeding 70 kW).
- BS. 5440:2** Ventilation (for gas appliances of rated input not exceeding 70 kW).
- BS. 5449** Forced circulation hot water systems.
- BS. 5546** Installation of gas hot water supplies for domestic purposes (2nd Family Gases).
- BS. 6798** Installation of gas fired hot water boilers of rated input not exceeding 60 kW.
- BS. 6891** Low pressure installation pipes.

### Health & Safety Document No. 635

### The Electricity at Work Regulations, 1989.

The manufacturer's notes must NOT be taken, in any way, as overriding statutory obligations.

**IMPORTANT.** These appliances are CE certificated for safety and performance. It is, therefore, important that no external control devices, e.g. flue dampers, economisers etc., are directly connected to these appliances unless covered by these Installation and Servicing Instructions or as otherwise recommended by **Ideal Stelrad Group** in writing. If in doubt please enquire.

Any direct connection of a control device not approved by **Ideal Stelrad Group** may invalidate the certification and the normal appliance warranty. It could also infringe the Gas Safety Regulations and the above regulations.

## SAFE HANDLING OF SUBSTANCES

Care should be taken when handling the boiler insulation panels, which can cause irritation to the skin. No asbestos, mercury or CFCs are included in any part of the boiler or its manufacture.



# GENERAL

## LOCATION OF BOILER

The boiler must be installed on a flat and level floor, capable of adequately supporting the weight of the boiler and any ancillary equipment.

The boiler may be fitted on a combustible floor. Insulation is not necessary, unless required by the local authority.

For electrical safety reasons there must be no access from the back of the boiler.

**The boiler must not be fitted outside.**

### Timber Framed Buildings

If the boiler is to be fitted in a timber framed building it should be fitted in accordance with the Institute of Gas Engineering document IGE/UP/7:1998.

### Bathroom Installations

This appliance is rated **IP20**.

The boiler may be installed in any room or internal space, although particular attention is drawn to the requirements of the current IEE (BS.7671) Wiring Regulations and, in Scotland, the electrical provisions of the building regulations applicable in Scotland, with respect to the installation of the boiler in a room or internal space containing a bath or shower. For Ireland reference should be made to the current ETCI rules for electrical installations and I.S.813:2002.

If the appliance is to be installed in a room containing a bath or shower then, providing water jets are not going to be used for cleaning purposes (as in communal baths/showers), the appliance can be installed in Zone 3, as detailed in BS.7671.

### Compartment Installations

A compartment used to enclose the boiler should be designed and constructed specially for this purpose.

An existing cupboard or compartment may be used, provided that it is modified for the purpose.

In both cases details of essential features of cupboard / compartment design, including airing cupboard installation, are to conform to the following:

- BS. 6798. (No cupboard ventilation is required - see "Air Supply" for details).
- The position selected for installation **MUST** allow adequate space for servicing in front of the boiler.
- For the minimum clearances required for safety and subsequent service see Frame 2.
- This position **MUST** also permit the provision of a satisfactory flue termination.
- Boiler may be fitted under a worktop/surface. Boiler can be fitted behind a kitchen cupboard door without need for ventilation.

## GAS SUPPLY

The local gas supplier should be consulted, at the installation planning stage, in order to establish the availability of an adequate supply of gas. An existing service pipe must NOT be used without prior consultation with the local gas supplier. The boiler **MUST** be installed on a gas supply with a governed meter only.

A gas meter can only be connected by the local gas supplier or by a CORGI registered engineer. In IE by a Competent Person.

An existing meter should be checked, preferably by the gas supplier, to ensure that the meter is adequate to deal with the rate of gas supply required.

**N.B.** The principle of the 1:1 gas valve ensures that the **mexico HE** range is able to deliver their full output at inlet pressures down to 14mb. However if dynamic pressures below 20mb are experienced ensure this is adequate for **ALL** other gas appliances in the property.

## IMPORTANT.

Installation pipes **MUST** be fitted in accordance with BS. 6891. In IE refer to I.S.813:2002. Pipework from the meter to the boiler **MUST** be of an adequate size, i.e. no longer than 20m and not less than 15mm O.D.

The complete installation **MUST** be tested for gas soundness and purged as described in the above code.

## FLUE INSTALLATION

Plumbing will occur at the terminal so terminal positions which would cause a nuisance should be avoided.

The flue must be installed in accordance with the recommendations of BS.5440-1:2000. In IE refer to I.S.813:2002. The following notes are intended for general guidance.

1. The boiler **MUST** be installed so that the terminal is exposed to external air.
2. It is important that the position of the terminal allows the free passage of air across it at all times.
3. Minimum acceptable spacing from the terminal to obstructions and ventilation openings are specified in Table 3.

**Table 3 - Balanced Flue Terminal Position**

Flue Terminal Positions	Min. Spacing*
1. Directly below or alongside an opening window, air vent or other ventilation opening.	300mm (12")
2. Below guttering, drain pipes or soil pipes. <i>BS5440-1 2000</i>	25mm (1")* 75mm (3")
3. Below eaves. <i>BS5440-1 2000</i>	25mm (1")* 200mm (8")
4. Below balconies or a car port roof. <i>BS5440-1 2000</i>	25mm (1")* 200mm (8")
5. From vertical drain pipes or soil pipes. <i>BS5440-1 2000</i>	25mm (1")* 150mm (6")
6. From an internal or external corner or to a boundary along side the terminal. <i>BS5440-1 2000</i>	25mm (1")* 300mm (12")
7. Above adjacent ground, roof or balcony level.	300mm (12")
8. From a surface or a boundary facing the terminal.	600mm (24")
9. From a terminal facing a terminal.	1,200mm (48")
10. From an opening in a car port (e.g. door or window) into dwelling.	1,200mm (48")
11. Vertically from a terminal on the same wall.	1,500mm (60")
12. Horizontally from a terminal on the wall.	300mm (12")
<b>Vertical Terminals</b>	
13. Above the roof pitch with roof slope of all angles. Above flat roof.	300mm (12") 300mm (12")
14. From a single wall face. From corner walls.	600mm (24") 1000mm (40")
<b>Twin Flue Applications</b>	
15. Centre distance between air inlet and flue outlet ducts.	120mm (5")

\* Only one reduction down to 25mm is allowable per installation otherwise BS5440-1 2000 dimensions must be followed.

4. Where the lowest part of the terminal is fitted less than 2m (6'6") above a balcony, above ground or above a flat roof to which people have access, then the terminal **MUST** be protected by a purpose designed guard.

Ensure that the guard is fitted centrally.

Terminal guards are available from boiler suppliers. Ask for TFC Flue Guard Model No. K6 (round plastic-coated). In case of difficulty contact:

Grasslin (UK) Ltd.	Tel. +44(0) 01732 359 888
Tower House, Vale Rise	Fax. +44(0) 01732 354 445
Tonbridge. kent TN9 1TB	www.tfc-group.co.uk



## GENERAL

- The flue assembly shall be so placed or shielded as to prevent ignition or damage to any part of any building.
- The air inlet/products outlet duct and the terminal of the boiler MUST NOT be closer than 25mm (1") to combustible material. Detailed recommendations on the protection of combustible material are given in BS.5440-1:2000. In IE refer to I.S.813:2002.

### IMPORTANT.

It is essential to ensure, in practice, that products of combustion discharging from the terminal cannot re-enter the building or buildings through any openings into the building such as ventilators, windows, doors, or other sources of natural air infiltration, such as forced ventilation openings etc.

If products of combustion re-entry is identified or suspected this should be immediately investigated and corrected following the guidance provided in the current Gas Industry Unsafe Situation Procedure.

### TERMINAL

The terminal assembly can be adapted to accommodate various wall thicknesses. Refer to Frame 19.

### AIR SUPPLY

It is NOT necessary to have a purpose-provided air vent in the room or internal space in which the boiler is installed. Neither is it necessary to ventilate a cupboard or compartment in which the boiler is installed, due to the low surface temperatures of the boiler casing during operation; therefore the requirements of BS 6798, Clause 12, and BS 5440:2 may be disregarded. In IE the requirements of I.S.813:2002 may be disregarded.

### WATER CIRCULATION SYSTEM

#### IMPORTANT.

A minimum length of 1 metre of copper pipe MUST be fitted to both flow and return connections from the boiler before connection to any plastic piping.

For boiler outputs greater than 60,000 btu/h (17.6 kW) the flow and return pipework should be connected in 28mm pipe.

For the types of system and correct piping procedure see Frames 1, and 3 to 8.

The central heating system should be in accordance with BS.6798 and, in addition, for smallbore and microbore systems, BS.5449.

#### WATER TREATMENT - see Frame 9

The hot water storage cylinder MUST be of the indirect type and should preferably be manufactured of copper.

Graph 1 - Water flow rate and pressure loss

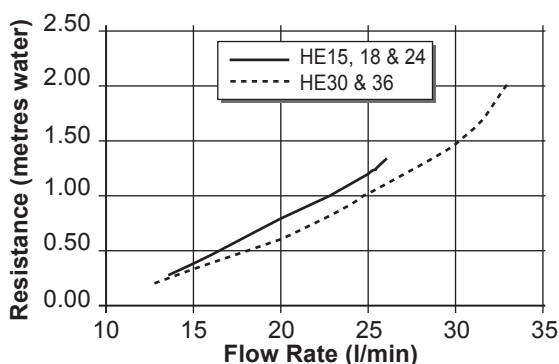

Single feed, indirect cylinders are not recommended and MUST NOT be used on sealed systems.

The appliances are NOT suitable for gravity central heating nor are they suitable for the provision of gravity domestic hot water.

The hot water cylinder and ancillary pipework, not forming part of the useful heating surface, should be lagged to prevent heat loss and any possible freezing - particularly where pipes run through roof spaces and ventilated underfloor spaces.

The boiler must be vented.

The hydraulic resistance of the boilers, at MAXIMUM OUTPUT, is shown in Graph 1.

### BOILER CONTROL INTERLOCKS

**Ideal Stelrad Group** recommend that heating systems utilising full thermostatic radiator valve control of temperature in individual rooms should also be fitted with a room thermostat controlling the temperature in a space served by radiators not fitted with such a valve as stated in BS. 5449.

Central heating systems controls should be installed to ensure the boiler is switched off when there is no demand for heating or hot water.

When thermostatic radiator valves are used, the space heating temperature control over a living / dining area or hallway having a heating requirement of at least 10% of the boiler heat output should be achieved using a room thermostat, whilst other rooms are individually controlled by thermostatic radiator valves. However, if the system employs thermostatic radiator valves on all radiators, or two port valves without end switches, then a bypass circuit must be fitted with an automatic bypass valve to ensure a flow of water should all valves be in the closed position.

### ELECTRICAL SUPPLY

#### WARNING.

This appliance must be earthed.

Wiring external to the appliance MUST be in accordance with the current I.E.E. (BS.7671) Wiring Regulations and any local regulations which apply. For Ireland reference should be made to the current ETCI rules for electrical installations.

The point of connection to the mains should be readily accessible and adjacent to the boiler.

**N.B. THE FAN VOLTAGE IS 325V DC.**

### CONDENSATE DRAIN - Refer to Frames 13, 15 and 18

A condensate drain is provided on the boiler. This drain must be connected to a drainage point. All pipework and fittings in the condensate drainage system MUST be made of plastic - no other materials may be used.

#### IMPORTANT.

Any external runs must be insulated.

The drain outlet on the boiler is standard 21.5mm (3/4") overflow pipe.

A condensate pump kit is available if required which may be fitted inside the boiler casing.

# GENERAL

## 3 OPEN VENT SYSTEM REQUIREMENTS

The system should be vented directly off the boiler flow pipe, as close to the boiler as possible. The cold feed entry should be inverted and **MUST** be positioned between the pump and the vent, and not more than 150mm (6") away from the vent connection.

**Note.** Combined feed and vent pipes may also be fitted.

There should be a minimum height 450mm (18") of open vent above the cistern water level. If this is not possible refer to Frame 5. The vertical distance between the highest point of the system and the feed/expansion cistern water level **MUST** not be less than 450 mm (18"). The pump must be fitted on the flow side of the boiler.

A suitable pump is a domestic circulator capable of providing a maximum 11°C (20°F) temperature differential across the boiler with the whole of the heating circuit open (e.g. Grundfos UPS 15/50, 15/60 or equivalent). With the minimum flow circuit allowed by the controls the differential must not exceed 25 °C. (18°C for the HE15)

The vertical distance between the pump and feed/expansion cistern **MUST** comply with the pump manufacturer's minimum requirements, to avoid cavitation. Should these conditions not apply either lower the pump position or raise the cistern above the minimum requirement specified by **Ideal Stelrad Group**. The isolation valves should be fitted as close to the pump as possible.

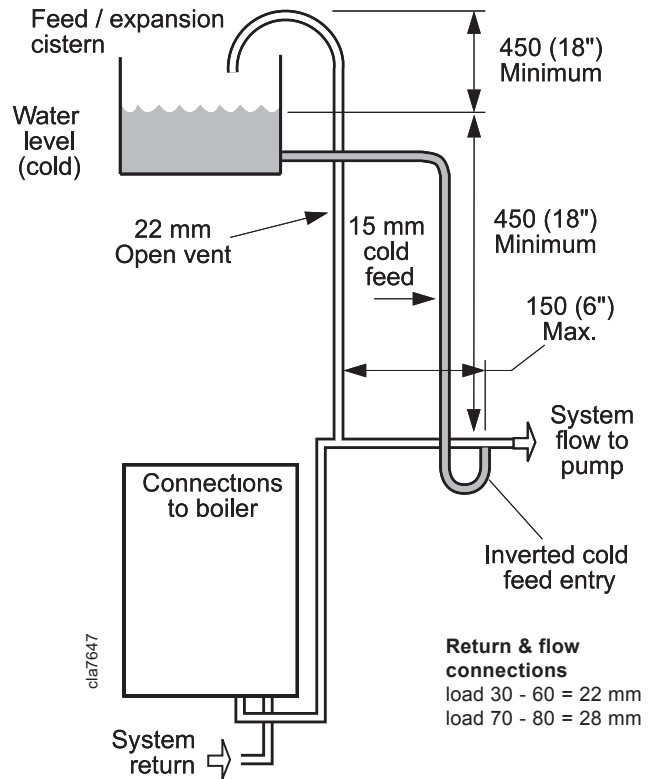

## 4 SCHEMATIC PIPEWORK AND SYSTEM BALANCING

The boiler does not normally need a bypass but at least some radiators on the heating circuit, of load at least 10% of the minimum boiler output, must be provided with twin lockshield valves so that this minimum heating load is always available (see footnote re. thermostatic radiator valves).

### Balancing

1. Set the programmer to ON for both CH and HW. Turn the cylinder thermostat down. Close the manual or thermostatic valves on all radiators, leaving the twin lockshield valves (on the radiators referred to above) in the open position. Turn up the room thermostat and adjust these lockshield valves to give boiler flow and return temperatures not more than 20 °C apart. These valves should now be left as set.
2. Open all manual or thermostatic radiator valves and adjust the lockshield valves on remaining radiators to give around 11°C temperature drop at each radiator.
3. Turn up the cylinder thermostat and adjust the cylinder balancing valve so that the cylinder achieves a maximum flow consistent with adequate flow to the radiators. Check that with only the domestic hot water loop in circuit a differential temperature of 20 °C across the boiler is not exceeded.
4. Adjust room and cylinder thermostats and programmer to NORMAL settings.

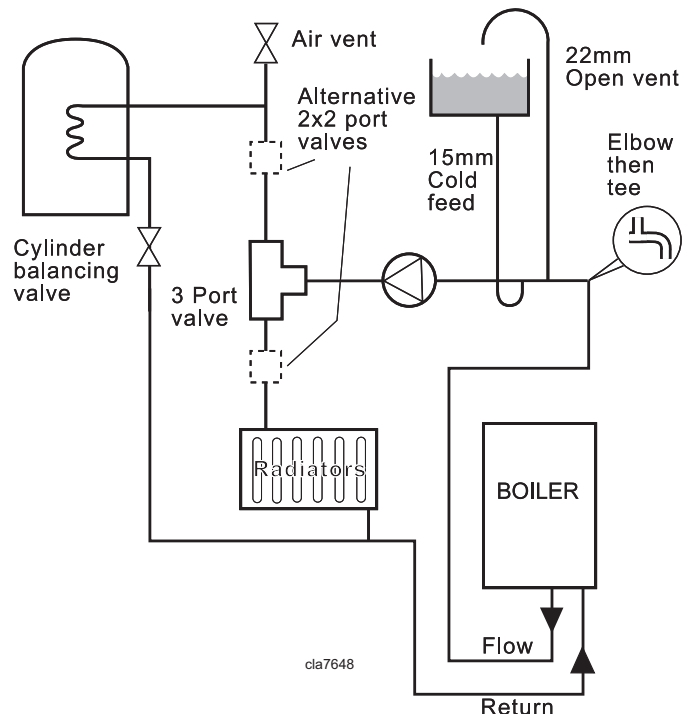

## GENERAL

### 5 LOW HEAD AND LARGE SYSTEMS WITH EXTENSIVE PIPE RUNS - OPEN VENT

This arrangement is useful for large systems where radiators at the extremities are difficult to vent. This can lead to pumping over with conventional feed and vent arrangements.

The following conditions **MUST** be observed:

1. The top of the automatic air vent must be below the cold water level.
2. The static water level (cold) must be at least 200mm above the top of the horizontal flow pipe, fitted as shown. The vent connection **MUST NOT** be made immediately off the top of the boiler as venting is made less efficient.
3. The maximum practical length of 22mm cold feed pipe should be used in order to reduce the effective volume of hot system water expanding into the feed/expansion cistern to a minimum.

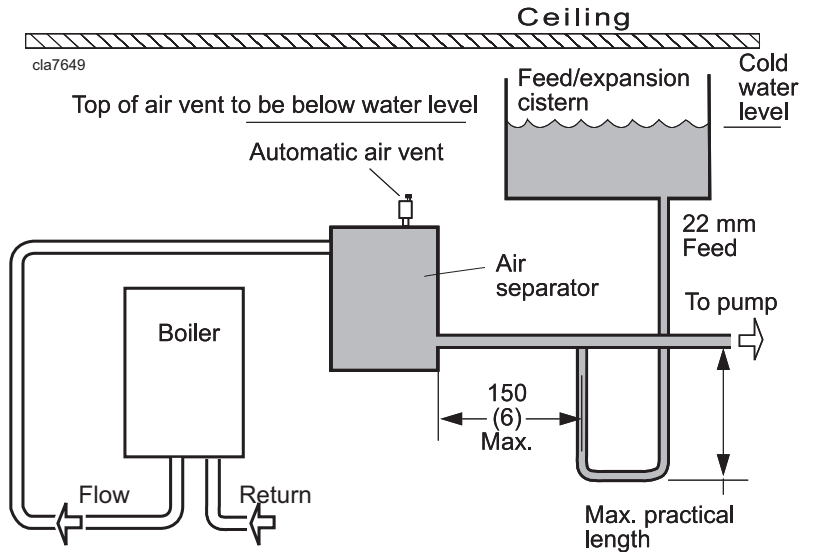

**Note.** The pump manufacturers' minimum requirements must be complied with.

All dimensions in mm (in.).

**NB.** Imperial dimensions are approximate

### 6 SEALED SYSTEM REQUIREMENTS

#### Notes.

- a. The method of filling, refilling, topping up or flushing sealed primary hot water circuit from the mains via a temporary hose connection is only allowed if acceptable to the local water authority.
- b. When installing the filling device, it must be connected as shown to fully comply with the water regulations. This may involve the fitting of an additional WRAS approval isolator valve to the mains supply.

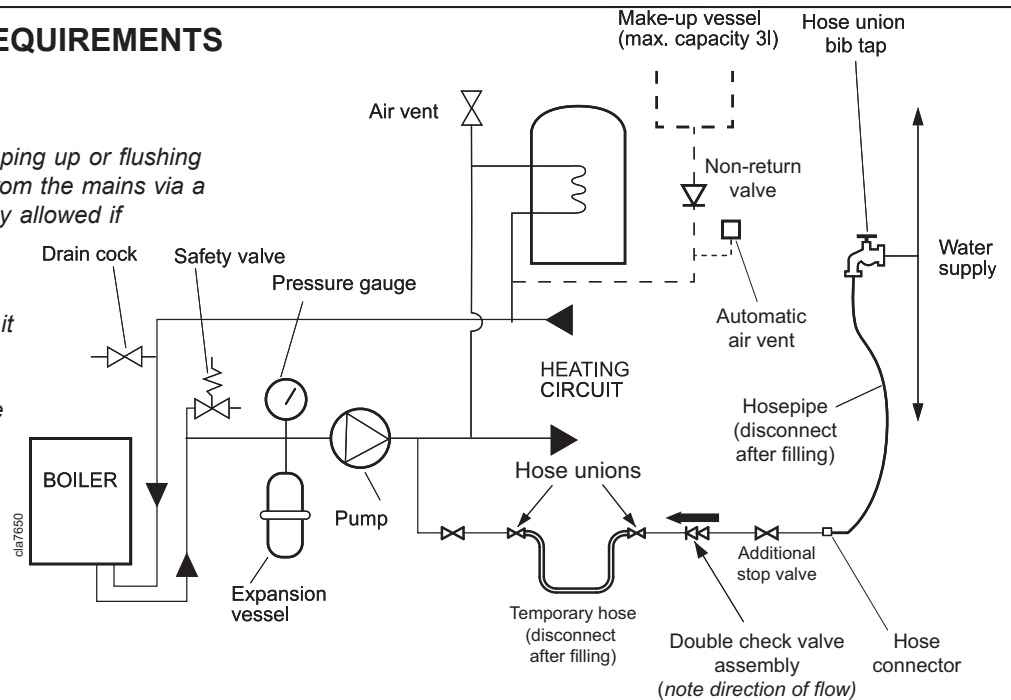

#### 1. General

- a. The installation must comply with the requirements of BS. 6798 and BS. 5449.
- b. The installation should be designed to work with flow temperatures of up to 82 °C.
- c. All components of the system, including the heat exchanger of the indirect cylinder, must be suitable for a working pressure of 3 bar (45lb/in<sup>2</sup>) and temperature of 110°C. Care should be taken in making all connections so that the risk of leakage is minimised.

#### 2. Safety Valve

A spring loaded safety valve complying with the relevant requirements of BS. 6759 must be fitted in the flow pipe as close to the boiler as possible and with no intervening valve or restriction. The valve should have the following features:

- a. A non-adjustable preset lift pressure not exceeding 3bar (45lb/in<sup>2</sup>).
- b. A manual testing device.
- c. Provision for connection of a discharge pipe. *The valve or discharge pipe should be positioned so that the discharge of water or steam cannot create a hazard to the occupants of the premises or cause damage to electrical components and wiring.*

#### 3. Pressure Gauge

A pressure gauge covering at least the range 0-4 bar (0-60 lb/in<sup>2</sup>) must be fitted to the system. The gauge should be easily seen from the filling point and should preferably be connected at the same point as the expansion vessel.

**7 SEALED SYSTEM REQUIREMENTS - continued**

**4. Expansion Vessel**

- a. A diaphragm type expansion vessel must be connected to a point close to the inlet side of the pump, the connecting pipe being not less than 15 mm (1/2" nominal) size and not incorporating valves of any sort.
- b. The vessel capacity must be adequate to accept the expansion of the system water when heated to 110°C (230°F).
- c. The charge pressure must not be less than the static water head above the vessel. The pressure attained in the system when heated to 110° C (230° F) should be at least 0.35 bar (5 lb/in<sup>2</sup>) less than the lift pressure of the safety valve.  
For guidance on vessel sizing refer to the table in Frame 8.

For further details refer to BS. 5449, BS. 7074:1 and the British Gas Corporation publication 'Material and Installation Specifications for Domestic Central Heating and Hot Water'. For IE refer to the current edition of I.S.813.

**5. Cylinder**

The cylinder must be either of the indirect coil type or a direct cylinder fitted with an immersion calorifier which is suitable for operating on a gauge pressure of 0.35 bar (5 lb/in<sup>2</sup>) in excess of the safety valve setting. Single feed indirect cylinders are not suitable for sealed systems.

**6. Make-up Water**

Provision must be made for replacing water loss from the system, either:

- a. From a manually filled make-up vessel with a readily visible water level. The vessel should be mounted at least 150 mm (6") above the highest point of the system, and be connected through a non-return valve to the system, fitted at least 300 mm (12") below the make-up vessel on the return side of the domestic hot water cylinder or radiators.  
or
- b. Where access to a make-up vessel would be difficult by pre-pressurisation of the system. Refer to 'Filling', below.

**7. Mains Connection**

There must be no direct connection to the mains water supply or to the water storage tank supplying domestic water, even through a non-return valve, without the approval of the local water authority.

**8. Filling**

The system may be filled by one of the following methods:

- a. Through a cistern, used for no other purposes, via a ball valve permanently connected directly to a service pipe and/or a cold water distributing pipe.  
The static head available from the cistern should be adequate to provide the desired initial system design

pressure. The cold feed pipe from the cistern should include a non-return valve and a stop valve with an automatic air vent connected between them, the stop valve being located between the system and the automatic air vent. The stop valve may remain open during normal operation of the system if automatic water make-up is required.

- b. Through a self-contained unit comprising a cistern, pressure booster pump (if required) and, if necessary, an automatic pressure reducing valve and flow restrictor. The cistern should be supplied through a temporary connection from a service pipe or cold water distributing pipe.  
This unit may remain permanently connected to the heating system to provide limited automatic water make-up. Where the temporary connection is supplied from a service pipe or distributing pipe which also supplies other draw-off points at a lower level than a double check valve shall be installed upstream of the draw-off point.
- c. Through a temporary hose connection from a draw-off tap supplied from a service pipe under mains pressure. Where the mains pressure is excessive a pressure reducing valve shall be used to facilitate filling.

The following fittings shall form a permanent part of the system and shall be fitted in the order stated:

A stop valve complying with the requirements of BS. 1010, Part 2 (the hose from the draw-off tap shall be connected to this fitting).

A test cock.

A double check valve of an approved type.

- Thoroughly flush out the whole of the system with cold water, without the pump in position.
- With the pump fitted, fill and vent the system until the pressure gauge registers 1.5 bar (21.5lb/in<sup>2</sup>).  
Examine for leaks.
- Check the operation of the safety valve by manually raising the water pressure until the valve lifts. This should occur within ± 0.3 bar (± 4.3lb/in<sup>2</sup>) of the preset lift pressure.
- Release water from the system until the initial system design pressure is reached.
- Light the boiler and heat the system to the maximum working temperature. Examine for leaks.
- Turn off the boiler and drain the system while still hot.
- Refill and vent the system.
- Adjust the initial pressure to the required value.

**Sizing procedure for expansion vessels:** The volume of the expansion vessel (litres) fitted to a sealed system shall not be less than that given by the table on the following page, multiplied by a factor of 0.8 (for flow temperatures of less than 83° C).

## GENERAL

### 8 SEALED SYSTEM REQUIREMENTS - continued

Safety valve setting	3.0 bar			2.5 bar			2.0 bar	
Vessel charge and initial system pressure	0.5 bar	1.0 bar	1.5 bar	0.5 bar	1.0 bar	1.5 bar	0.5 bar	1.0 bar
Total water content of system litres	Expansion vessel volume litres							
<b>25</b>	2.1	2.7	3.9	2.3	3.3	5.9	2.8	5.0
<b>50</b>	4.2	5.4	7.8	4.7	6.7	11.8	5.6	10.0
<b>75</b>	6.3	8.2	11.7	7.0	10.0	17.7	8.4	15.0
<b>100</b>	8.3	10.9	15.6	9.4	13.4	23.7	11.3	20.0
<b>125</b>	10.4	13.6	19.5	11.7	16.7	29.6	14.1	25.0
<b>150</b>	12.5	16.3	23.4	14.1	20.1	35.5	16.9	30.0
<b>175</b>	14.6	19.1	27.3	16.4	23.4	41.4	19.7	35.0
<b>200</b>	16.7	21.8	31.2	18.8	26.8	47.4	22.6	40.0
<b>225</b>	18.7	24.5	35.1	21.1	30.1	53.3	25.4	45.0
<b>250</b>	20.8	27.2	39.0	23.5	33.5	59.2	28.2	50.0
<b>275</b>	22.9	30.0	42.9	25.8	36.8	65.1	31.0	55.0
<b>300</b>	25.0	32.7	46.8	28.2	40.2	71.1	33.9	60.0
<b>Multiplying factors for other system volumes</b>	0.0833	0.109	0.156	0.094	0.134	0.237	0.113	0.20

### 9 WATER TREATMENT

The mexico HE boiler range have an ALUMINIUM alloy heat exchanger

**IMPORTANT.** The application of any other treatment to this product may render the guarantee of Ideal Stelrad Group invalid.

**Ideal Stelrad Group** recommend water treatment in accordance with the *Benchmark* Guidance Notes on Water Treatment in Central Heating systems.

**Ideal Stelrad Group** recommend the use of FERNOX-COPAL or MB1,GE Betz Sentinel X100 OR Salamander Corrosion Guard inhibitors and associated water treatment, which must be used in accordance with the manufacturers' instructions. For further information contact:

Fernox Manufacturing Co. Ltd  
Cookson Electronics  
Forsyth Road  
Sheerwater  
Woking  
Surrey  
GU21 5RZ  
Tel: +44 (0) 1799 521133

Sentinel Performance Solutions  
The Heath Business & Technical Park  
Runcorn  
Cheshire  
WA7 4QX  
Tel: 0800 389 4670  
www.sentinel-solutions.net

Salamander Engineering Ltd  
Unit 24  
Reddicap Trading Estate  
Sutton Coldfield  
West Midlands  
B75 7BU  
Tel: +44 (0) 121 3780952

#### Notes

1. It is most important that the correct concentration of the water treatment product is maintained in accordance with the manufacturers' instructions.
2. If the boiler is installed in an existing system any unsuitable additives **MUST** be removed by thorough cleansing.  
  
*BS. 7593:1992 details the steps necessary to clean a domestic central heating system.*
3. In hard water areas, treatment to prevent lime scale may be necessary - however, the use of artificially softened water is **NOT** permitted.
4. Under no circumstances should the boiler be fired before the system has been thoroughly flushed.



# INSTALLATION

## 10 BOILER ASSEMBLY - Exploded view

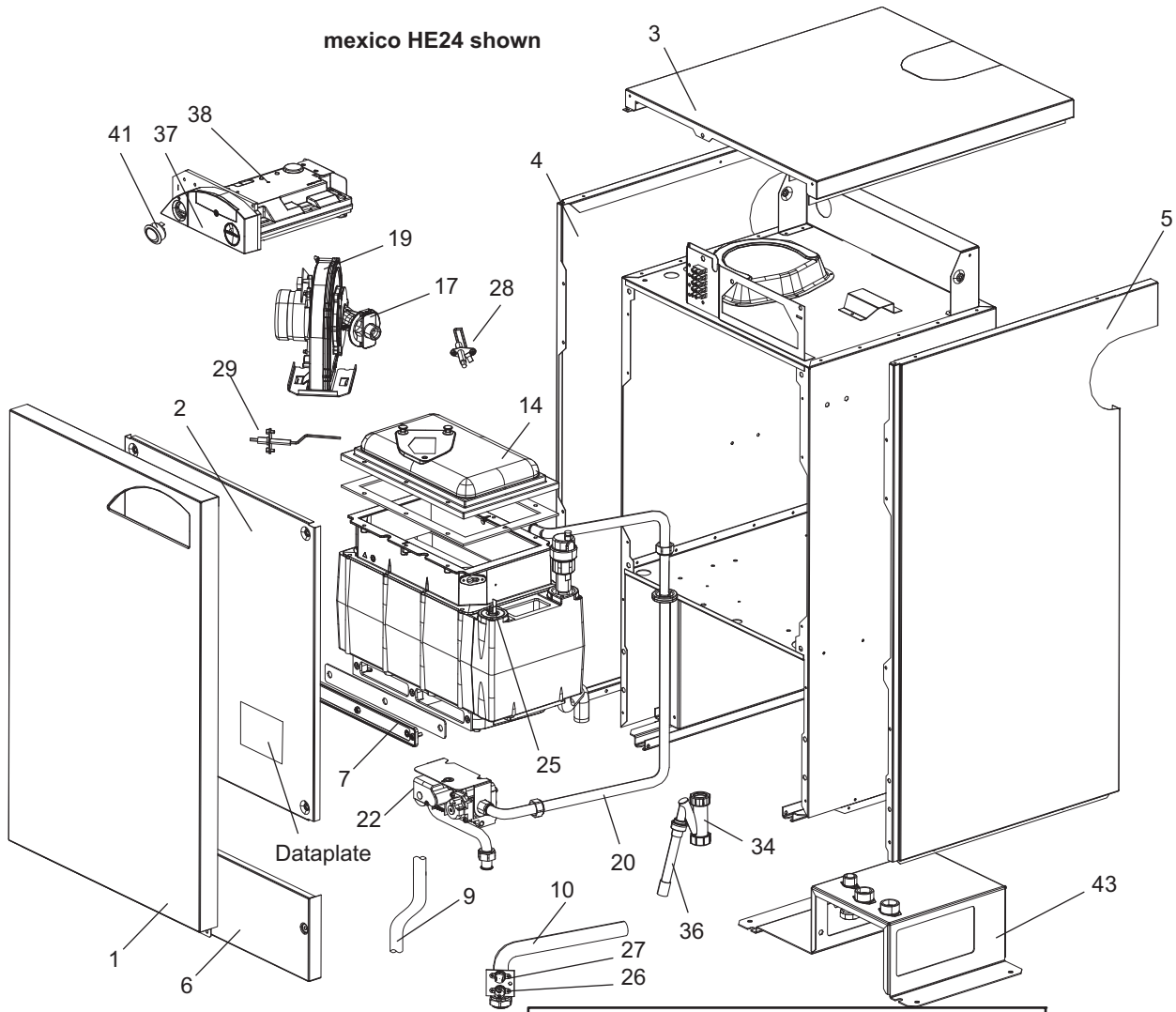

mxhe7922

### mexico HE36 heat exchanger

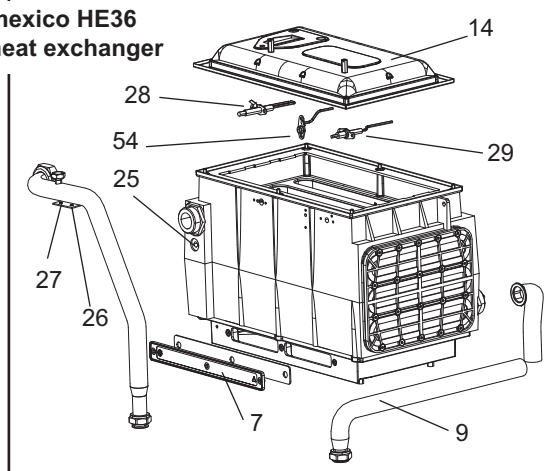

### LEGEND

- |                        |                        |  |
|------------------------|------------------------|--|
| 1 Front casing panel   | 14 Burner assembly     | 29 Flame detection electrode           |
| 2 Sealing panel        | 17 Injector & housing  | 34 Condensate 'S' trap                 |
| 3 Top casing panel     | 19 Fan assembly        | 36 Condensate 'S' trap hose            |
| 4 LH casing side panel | 20 Gas pipe assembly   | 37 User controls                       |
| 5 RH casing side panel | 22 Gas valve assembly  | 38 PCB primary control                 |
| 6 Lower front panel    | 25 Dry fire thermistor | 41 Main switch c/w harness             |
| 7 Sump cover plate     | 26 Control thermistor  | 43 Pre-piping frame                    |
| 9 Return pipe          | 27 Overheat thermostat | 54 Burner earth pin (ionisation probe) |
| 10 Flow pipe           | 28 Ignition electrode  |  |

# INSTALLATION

## 11 UNPACKING

The boiler is supplied fully assembled in one Pack A, together with a standard flue assembly for lengths up to 650mm, rear or side flue outlet, in Pack B.

**Unpack and check the contents.**

### Pack A Contents

- A The boiler
- B These Installation & Servicing/ User Instructions
- C Floor standing template
- D 1 year guarantee form
- E Hardware Pack Box

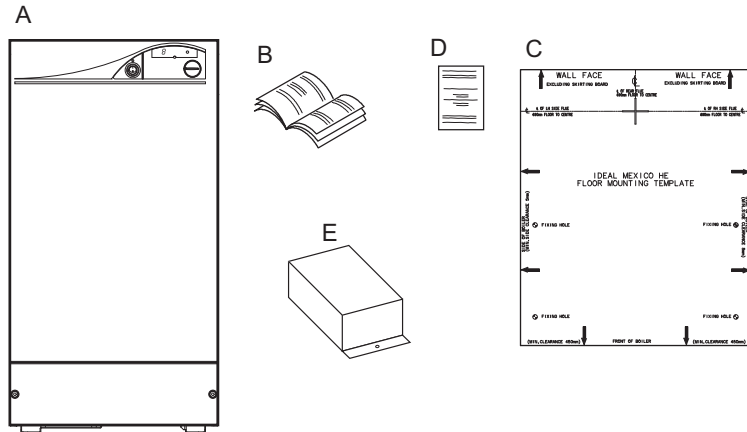

mxhe7570

### Hardware Pack Box Contents (E)

- A Pre-piping frame
- B Flue turret
- C Screws - 4 off
- D Gasket
- E Flue connector
- F Screws - 5 off
- G Condensate Pipe Bracket
- H Flue turret lubricant
- I Sealing washers - 3 off  
(1 x 1/2" gas and 2 x 22mm water connection)

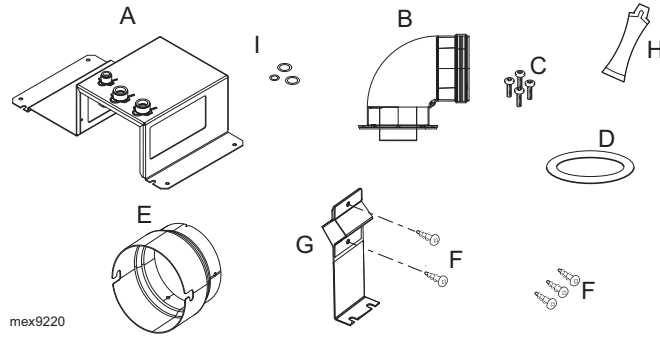

mex9220

### Pack B Contents

- Flue terminal

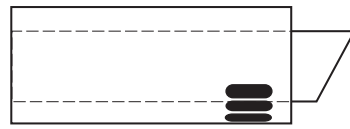

mxhe7658

## 12 PACKAGING REMOVAL

1. Fold back the top flaps and remove outer sleeve.
2. The Installation & Servicing/Users Instructions can be found on top of the boiler.
3. Remove wood screw at bottom rear of boiler, retaining the hardware pack box and remove box.
4. When the boiler is to be fitted to the pre piping Frame (refer to Frame 21) remove the top and inner sleeve and the boiler from its wooden base.

**The inner sleeve can be used to protect the floor when fitting the boiler to the pre-piping frame.**

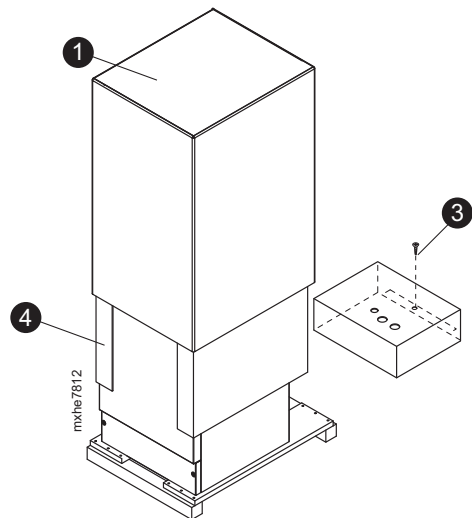

mxhe7812



# INSTALLATION

## 13 FITTING AND CONNECTING THE PRE-PIPING FRAME/CONDENSATE PIPE SUPPORT BRACKET

1. Determine the position required for the boiler and tape template into place.

**Note.**

The template gives positions for both wall or flush with 600mm deep kitchen units and the positional options of the condensate pipe bracket dependent upon boiler size. To facilitate upward routing of pipework behind boiler, position the template 40mm (minimum) away from the back wall.

2. Using the floor template, mark the pre-piping frame fixing holes, the boiler fixing holes, the condensate pipe support bracket fixing holes and the flue hole (refer to Frame 14).

3. Drill the 4 holes in the floor and screw the pre-piping frame in place.

4. Drill the 2 holes in the floor and screw the condensate pipe support bracket in place. If the condensate pipe is to be fitted through the rear wall then fit a short piece of plastic pipe to the bracket and mark the wall for drilling. Refer to Frame 15 for condensate drain detail. When complete retain condensate pipe with bracket clamp and fixing screws, protruding 20mm as shown.

5. The gas, water flow and water return can now be connected.

**Note.**

Measure and cut out flue hole using template (Refer to Frame 14).

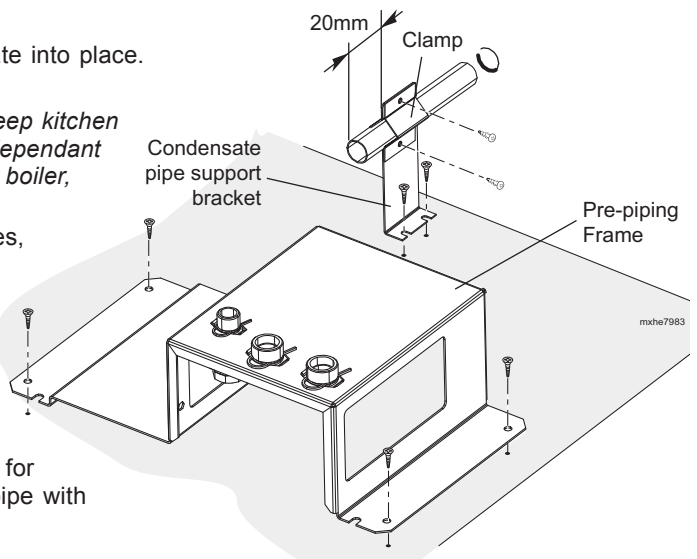

## 14 FLUE HOLE TEMPLATE

**IMPORTANT.** Ensure that, during the cutting operation, masonry falling outside of the building does not cause damage or personal injury.

**Note.**

The template shows the position of the flue hole centre lines. (Flue options can be flush to wall or in line with 600mm deep kitchen units)

1. Extend flue centre line vertically, (for rear, left or right as appropriate), up to 690mm (centre line of flue).

2. Mark onto the wall the position of the flue duct hole.

3. Cut the flue hole preferably with a 125mm (5") coreboring tool, ensuring that the hole is square to the wall.

4. Remove the template from the floor.

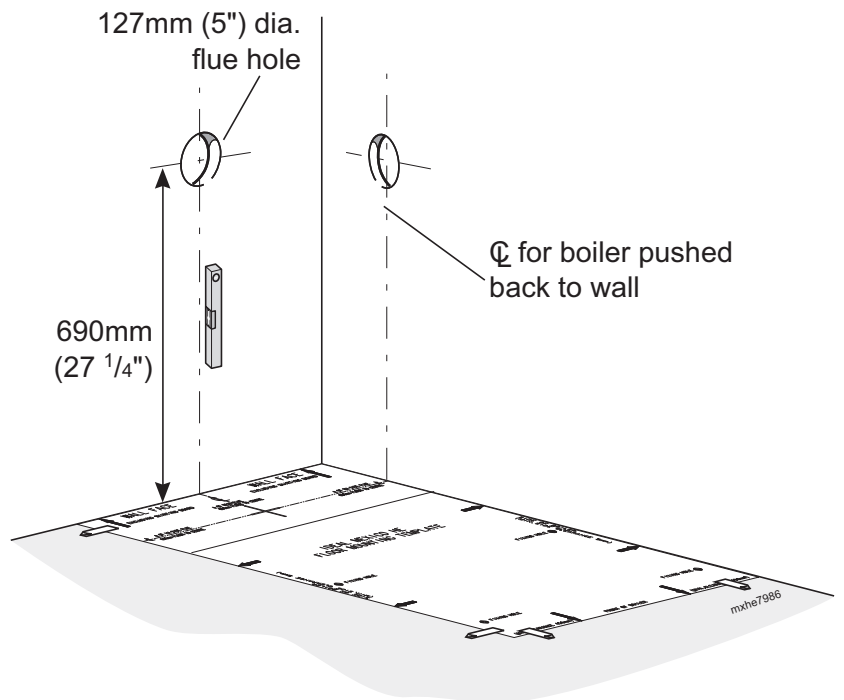

See wall mounting template

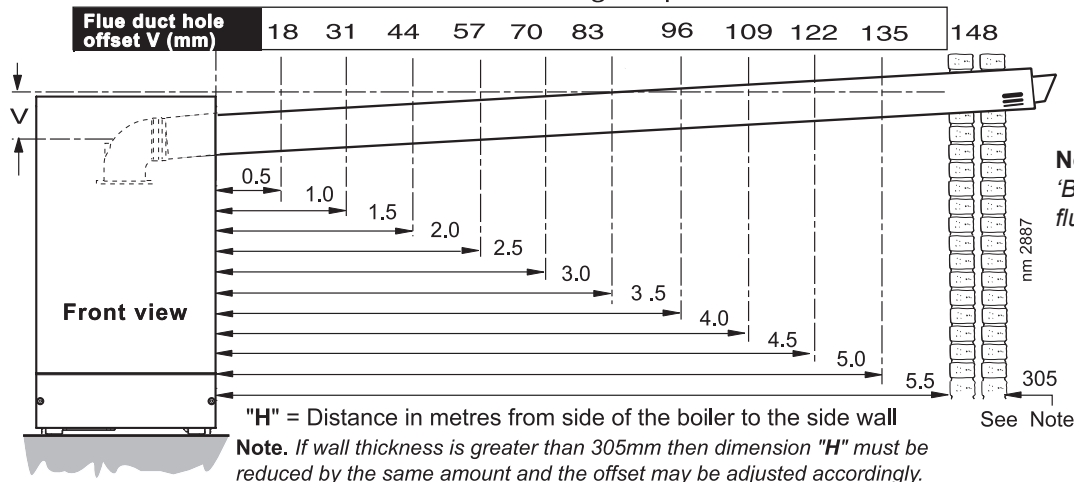

## 15 CONDENSATE DRAIN

Refer also to the British Gas document: 'Guidance Notes for the Installation of Domestic Gas Condensing Boilers' (1989).

Refer to Frame 21 for boiler condensate connection detail.

The condensate drain provided on the boiler must be connected to a drainage point, preferably within the building.

The routing of the drain must be made to allow a minimum fall of 1 in 20 away from the boiler, throughout its length. (Not including an additional trap)

The drainage pipework must be arranged so that obstruction (e.g. through freezing) of external drainage pipe does not give rise to spillage within the dwelling.

All pipework and fittings in the condensate drain system must be made of plastic. No other materials may be used.

The drain outlet on the boiler is standard 21.5mm overflow pipe. This size must not be reduced in any part of its length.

**Note.** A condensate drain pump kit is available as an optional extra if required.

## 16 GAS CONNECTION

The boiler gas connection is built into the pre-piping frame.

**IMPORTANT.** The gas service cock is sealed with a non-metallic fibre washer seal so must not be overheated when making capillary connections.

Refer to Frame 1 for details of the position of the gas connection.

**N.B.** The principle of the 1:1 gas valve ensures that the **mexico HE** range is able to deliver their full output at inlet pressures down to 14mb. However if dynamic pressures below 20mb are experienced ensure this is adequate for **ALL** other gas appliances in the property.

A boiler gas supply pipe length of 20m and not less than 15mm O.D. can be connected to the boiler via the gas service cock union.

Ensure that the gas supply pipe does not foul the boiler casing.

Refer to Frame 40 for details of the pressure test point position.

## 17 BOILER WATER CONNECTIONS

The boiler flow and return connections are built into the pre-piping frame.

**Note.**

*For heating loads in excess of 60 000 Btu/h use 28mm x 22mm connectors to connect the boiler flow and return pipes to 28mm.*

If flow and return pipes are required to run behind the boiler, this can be facilitated by fitting the boiler in line with the front of 600mm deep kitchen units thus creating a 70mm space behind the boiler.

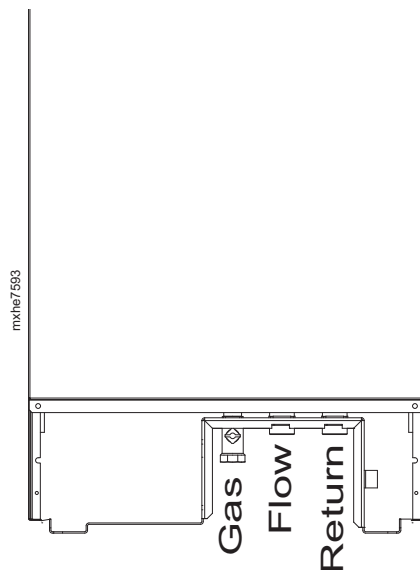

# INSTALLATION

## 18 CONDENSATE PIPE TERMINATION CONFIGURATIONS

*Note. ALL EXTERNAL PIPE RUNS MUST BE INSULATED - MAXIMUM LENGTH 3M EXTERNAL*

A condensate drain pump kit is available as an optional extra if required. (The kit includes instructions for system connection).

### 1. TERMINATION TO DRAIN / GULLY

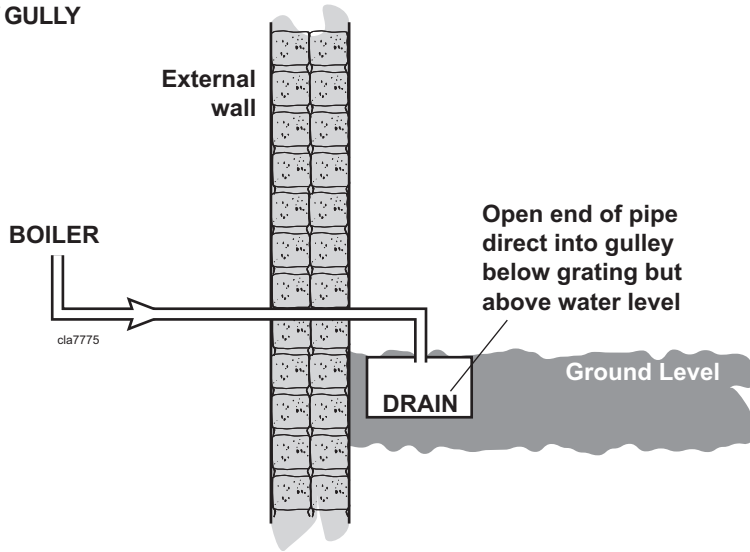

### 2. TERMINATION TO SOAK AWAY

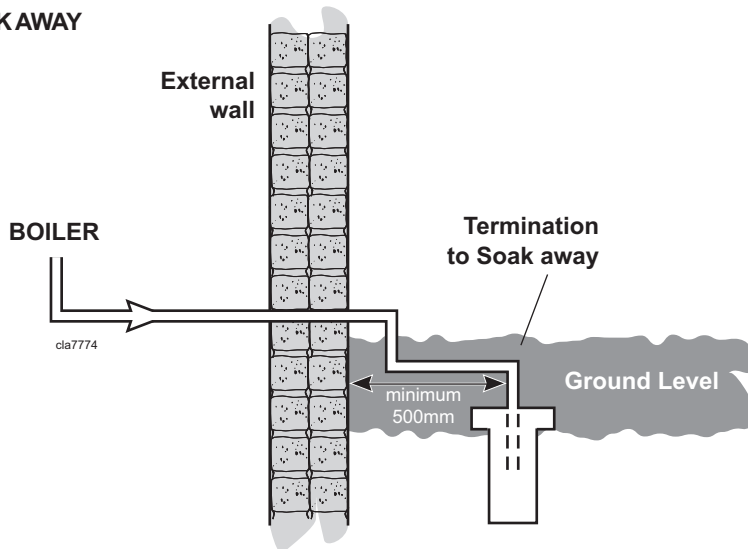

### 3. INTERNAL CONNECTION TO SOIL AND VENT STACK

Termination into a down pipe can take place providing it can be confirmed that the down pipe is part of a combined waste and rain water system.

\* Make connection to SVP using a solvent welded saddle.

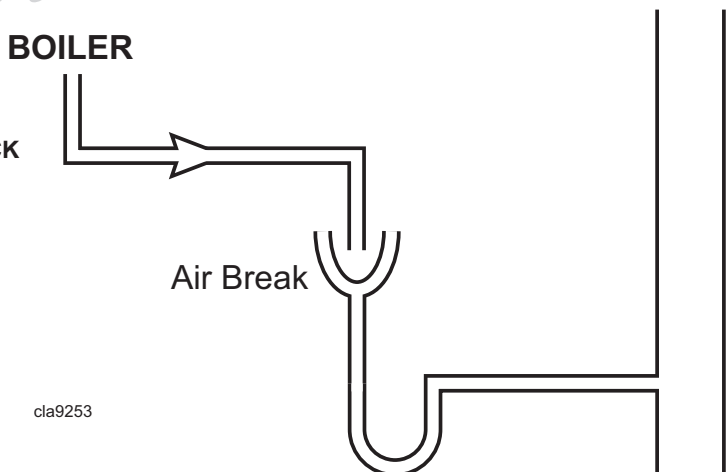

# INSTALLATION

## 19 DETERMINING THE FLUE LENGTH AND FLUE PACKS REQUIRED

**IMPORTANT.** The boiler MUST be installed in a vertical position

**Dimension X** - Wall thickness.

**Dimension L** - Wall thickness plus boiler spacing.

### FLUE KITS

**Pack B** - supplied as standard

**Finishing Kit** - supplied as an optional extra

**Pack D** - optional extension kit for side flue or rear flue outlet.

Refer to 'Flue Extension Ducts'.

**Note. MAXIMUM FLUE LENGTHS:**

**HE15, 18 AND 24** - 6M (HORIZONTAL FLUE)

**HE30 AND 36** - 3M (HORIZONTAL FLUE)

**HE15, 18 AND 24** - 8M (VERTICAL FLUE)

**HE 30 AND 36** - 5M (VERTICAL FLUE)

**90° ELBOW KIT (EQUIVALENT FLUE LENGTH RESISTANCE = 1.5M)**

**45° ELBOW KIT (EQUIVALENT FLUE LENGTH RESISTANCE = 1.0M)**

Total Flue length dimension		Flue
Rear flue dim. X+75	Side flue dim. L+225	Extra packs required
Up to 775 mm	Up to 775 mm	none
Up to 1680 mm	Up to 1680 mm	Pack D - 1 off
Up to 2585 mm	Up to 2585 mm	Pack D - 2 off
Up to 3490 mm	Up to 3490 mm	Pack D - 3 off
Up to 4395 mm	Up to 4395 mm	Pack D - 4 off
Up to 5300 mm	Up to 5300 mm	Pack D - 5 off
Up to 6000 mm	Up to 6000 mm	Pack D - 6 off

**Note.** The flue duct MUST be inclined at 1.5 degrees to the horizontal to allow condensate to drain back into the boiler and out through the condensate drain. (Only necessary if using one or more 'D' extension duct packs)

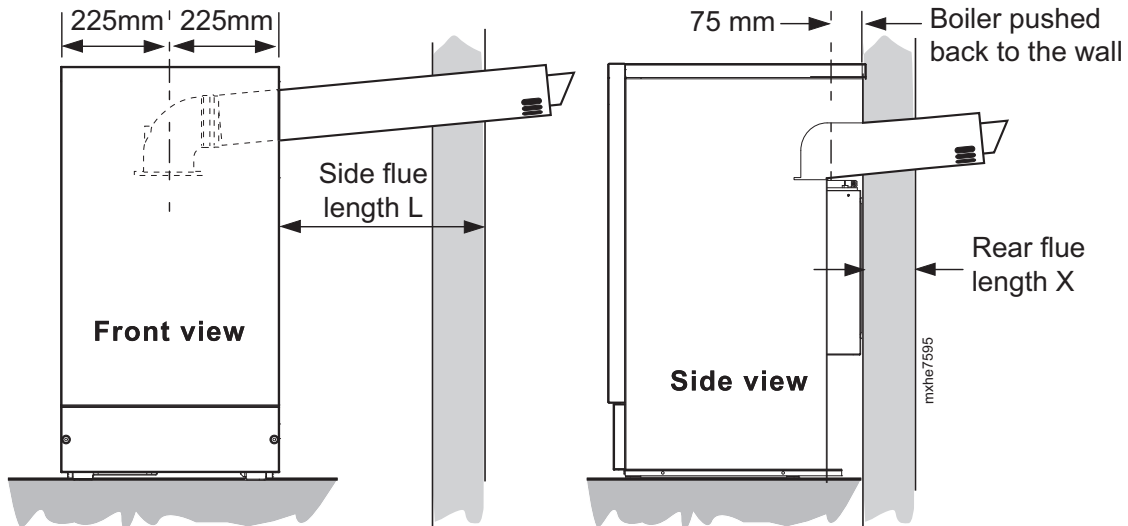

## 20 FLUE ASSEMBLY - Exploded View

An optional flue duct extension kit is required for wall thicknesses greater than :

**Side** 545mm (21 1/2")

**Rear** 705mm (27 3/4")

### LEGEND

1. Duct assembly
2. Flue turret
3. Turret fixing screws
4. Flue connector
5. Flue connector screws
6. Turret gasket
7. Foam sealing tape

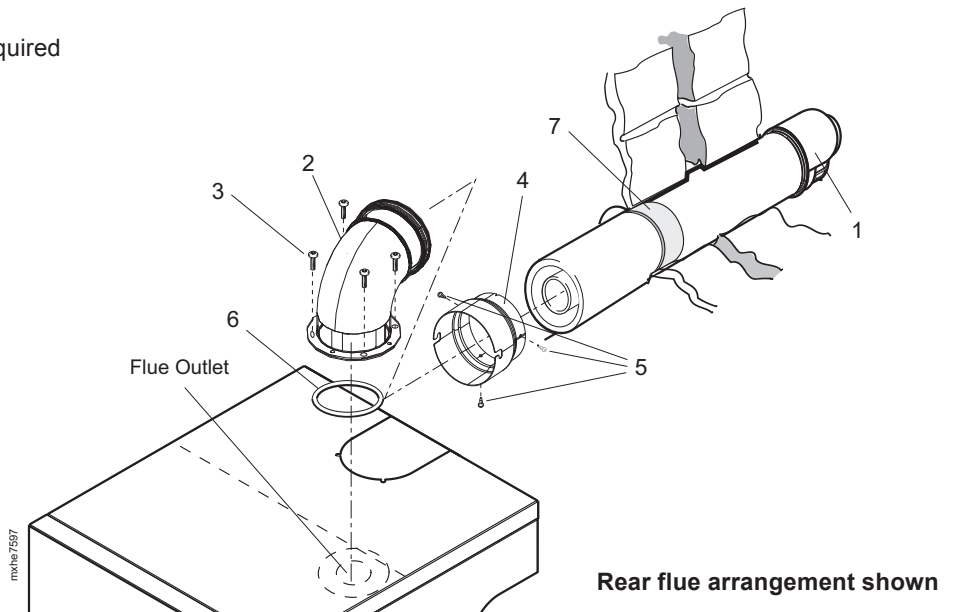

# INSTALLATION

## 21 MOUNTING THE BOILER ONTO THE PRE-PIPING FRAME

**NOTE. USE THE BOILER PACKAGING SLEEVE TO PROTECT THE FLOOR.**

1. Remove the two screws retaining the lower front panel and remove the panel
2. Remove the two screws retaining the upper front panel.
3. Lift the upper front panel and remove. If the optional extra concealment panel kit is to be fitted to either left or right hand side panel, it must NOW be fitted (refer to separate instructions provided with kit).
4. **At this stage fit the flue assembly and turret (see Frame 28 or 33) and in the case of rear flue fit the optional flue finishing kit, refer to Frame 27, if required. Remove the top panel to facilitate turret fitting.**
5. Fit the sealing washers to the water and gas connections.
6. If the condensate pump is to be used, it must now be fitted (If not to be fitted go to No. 7)
  - a. Fit the condensate pump fixing slots over the two screw heads. The screws position the pump but cannot be tightened.
  - b. Prepare to route the condensate pump cable, the mains cable and the remote user controls wiring (if required) up the rear of the boiler and through the grommet to be found at the top left of the boiler.
  - c. Using the rubber connecting joint, provide a plastic outlet pipe from the pump outlet connection, to a suitable drain point connection taking care to route the pipework such that it will not foul the boiler when fitted. Refer to Frame 18.
  - d. Make up the inlet plastic pipe connection to the following drawing and fit to the 'S' trap flexible hose connection.

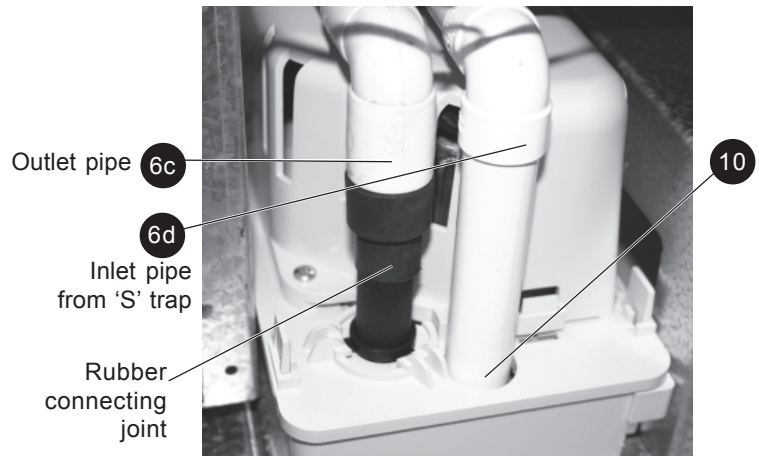
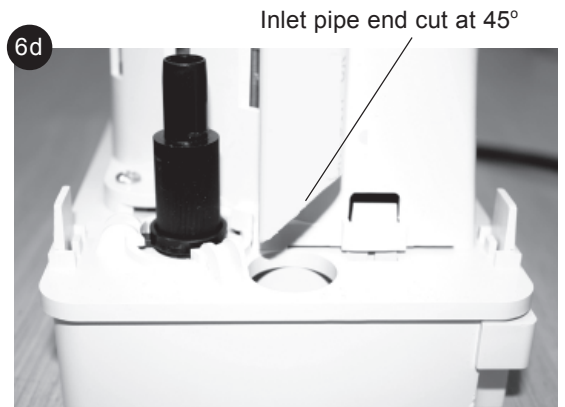
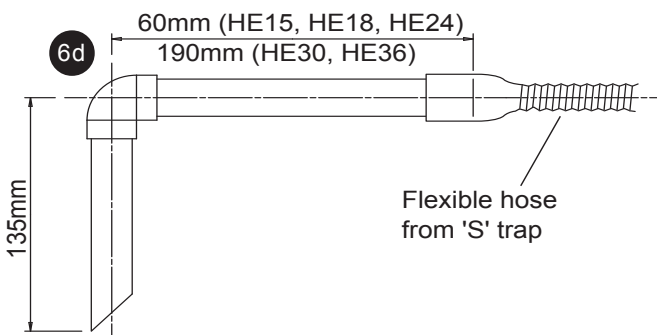
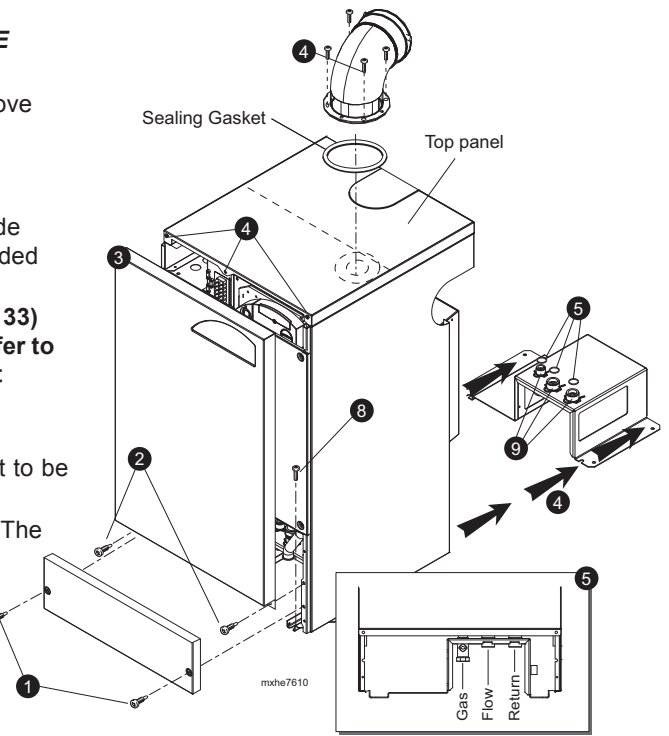

7. Remove the four screws retaining the boiler to the wooden packaging base and using the packaging sleeve to protect the floor, slide the boiler onto the pre-piping frame ensuring the mains cable and the condensate pump cable (if fitted) is routed through the grommet at the top left of the boiler.
8. Screw the boiler frame to the floor through the 2 slots in the front of the boiler runners.
9. Connect the gas and water union connections ensuring the sealing washers are in place.
10. Connect the condensate pump inlet ensuring the pipe is pushed to bottom of the pump housing. If no pump is fitted connect the S trap flexible hose to the previously installed condensate drain pipe. Refer to Frame 13.
11. Wire the mains connection, the condensate pump connection (if fitted) and the remote user control (if fitted). Refer to Frame 35.

FLUE OUTLET

# INSTALLATION

## 22 CUTTING THE FLUE - REAR Wall thicknesses of 114 to 705mm

**Note.**

If using the extension ducts go to Frame 24, 25 and 26.

1. Measure and note wall thickness X. Refer to Frame 19.
2. Add 5mm (1/4") to dimension X and, measuring from the ring, cut both outer and inner tube. Ensure support spring clip is in position to facilitate cutting.
3. To ensure the tube is cut square, mark the flue all the way around.
4. De-burr the cut edges.

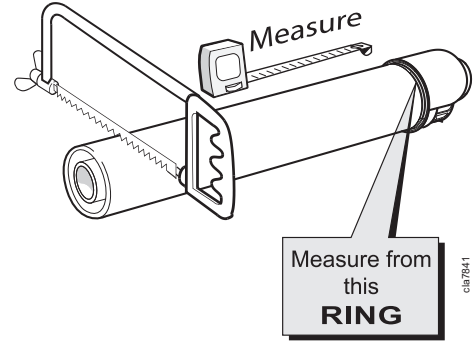

## 23 CUTTING THE FLUE LH OR TO RH SIDE - Wall thickness of 114 to 545mm

**Note.** If using the extension ducts go to Frame 24, 25 and 26.

1. Measure and note side flue length L. Refer to Frame 19.
2. Add 60mm (2<sup>3</sup>/<sub>8</sub>" ) to dimension L and measuring from the ring, cut both outer and inner tube. Ensure support spring clip is in position to facilitate cutting.
3. To ensure the tube is cut square, mark the flue all the way around.
4. De-burr the cut edges.

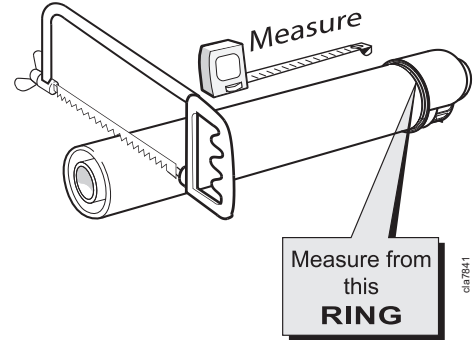

## 24 FLUE EXTENSION DUCTS - for flue lengths greater than 775mm

**Pack D Flue extension duct kit contents**

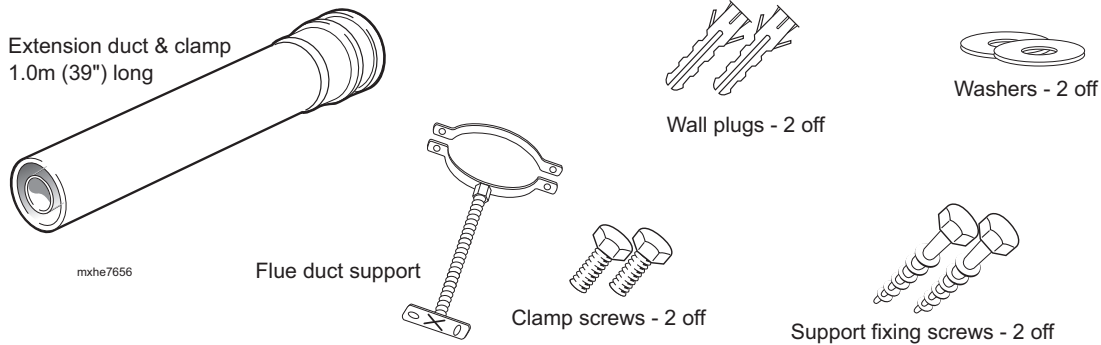

## 25 FLUE EXTENSION DUCTS - continued

**Use a maximum of 6m extended flue ONLY (HE15, HE18, HE24)**

**Use a maximum of 3m extended flue ONLY (HE30, HE36)**

**General arrangement**

1. A **maximum** of 6 extension ducts for the HE15, HE18 and HE24 and a **maximum of 3** extension ducts for the HE30 and HE36 (one suitably cut) plus the standard flue duct may be used together.
2. Flue extensions of greater length than 1m (39") should be supported with the bracket provided, suitably adjusted. Refer to Frame 24.

**Note.** Side flue shown

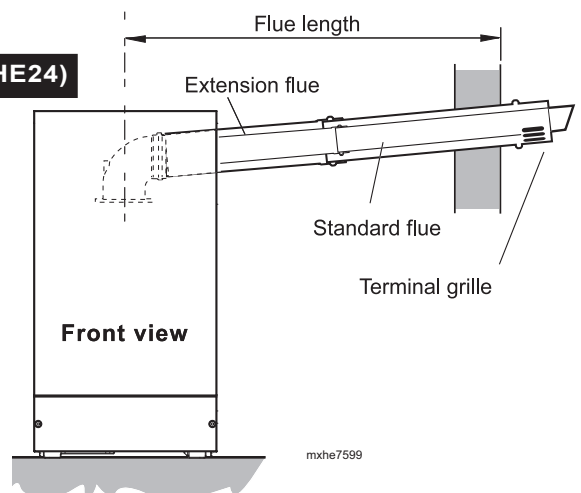



# INSTALLATION

## 26 FITTING THE KIT

1. Fit the inner flue extension duct onto the inner flue duct.
2. Fit the outer flue extension duct onto the outer air duct.
3. Repeat steps 1 and 2 if a second flue extension is required.
4. Measure and mark the flue length required onto the flue, measuring from the ring near the terminal. (Refer to Frames 19 and 23 for detail of length measurement)
5. To ensure a square cut, mark the flue all the way around.
6. De-burr the cut edges.

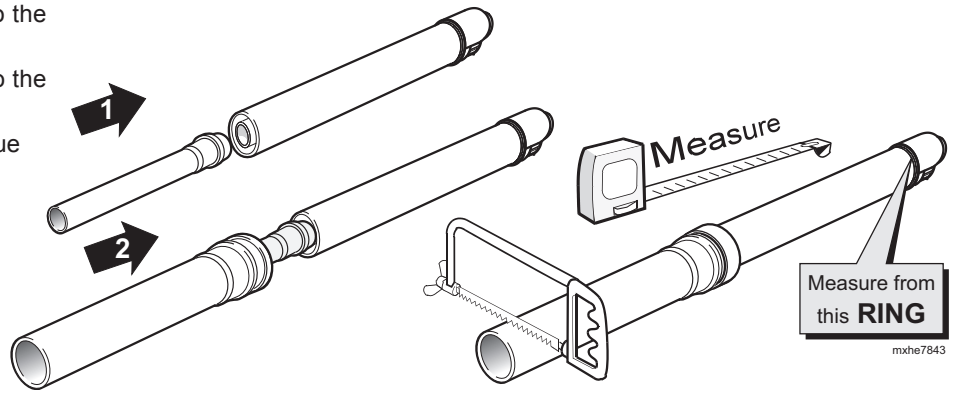

## 27 FITTING THE OPTIONAL FLUE FINISHING KIT AND OPTIONAL RS SEALING PLATE

### Flue Finishing Kit

1. Fit black outer wall seal over terminal and ensure the retaining rim is located in the terminal depression.
2. Fit flue pipe assembly through the hole previously cut in wall.
3. Fit white inner wall seal to pipe assembly (side flue).
4. Fit outer wall sealing plate over outer wall seal and retain with the 4 screws and wall plugs provided.

### Contents:

- Wall Seal White - 1 off
- Wall Seal Black - 1 off
- Wall Sealing Plate - 1 off
- Screws No. 10x2" - 4 off
- Wallplugs - 4 off

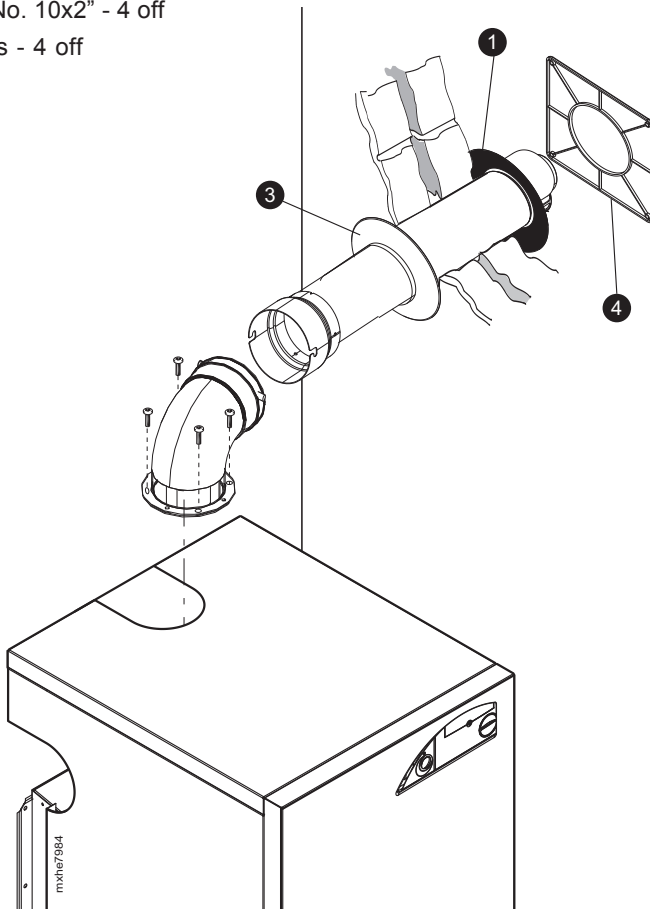

### RS Sealing Plate

If the Mexico HE is replacing a room sealed appliance, an optional extra terminal wall sealing plate is available to make good the rectangular flue hole.

### Contents:

- Wall Seal plate - 1 off
- Screws No. 10x2" Woodscrew - 4 off
- Wallplugs - 4 off

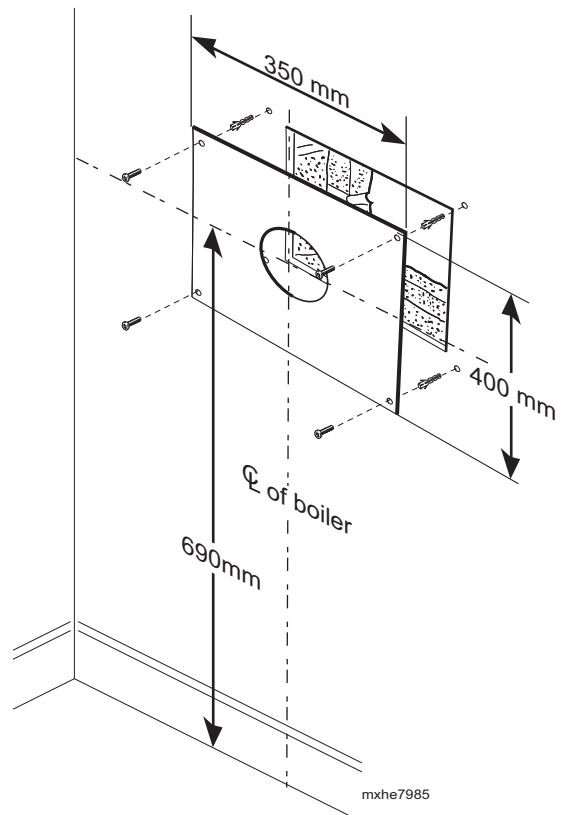



# INSTALLATION

## 28 CONNECTING THE FLUE TO THE BOILER

1. Measure 68mm from the cut end of the flue assembly and mark a line on the flue.
2. Fit the flue connector over the end of the flue and align the end of the connector with the marked line.
3. Ensure the 'V' cutout on the flue connector is aligned with the top of the turret (use label as a guide).
4. Mark the 3 fixing screw holes and drill the three holes with a 3.2 (1/8") dia drill. Do not drill through the inner flue pipe.
5. Retain the connector with the 3 screws provided.
6. Adhere the 70mm wide x 20mm deep foam strip (found in the hardware pack box) to the flue assembly tube to provide an inner seal to the hole cut in the wall.
7. Insert the flue assembly through the prepared hole in the wall.
8. Remove the top outlet blanking plate or boiler top panel to facilitate turret fitting. To ensure a positive flue seal is confirmed it may be necessary to remove the worktop or adjacent cupboard to view the joint.
9. Fit the sealing gasket and push the flue turret into the top of the boiler flue sealing ring and retain with the 4 screws provided.
10. **Smear lubricant (to be found in hardware pack)** over both inner flue duct seal and outer air duct seal and locate the flue onto the turret ensuring the 2 bayonet fixings on the flue connector (B) engage to the lugs on the turret (A).
11. Replace the top outlet blanking plate.
12. **Flues over 1 metre long.**  
Fix the flue support bracket to the wall, using the wall plug and wood screw.

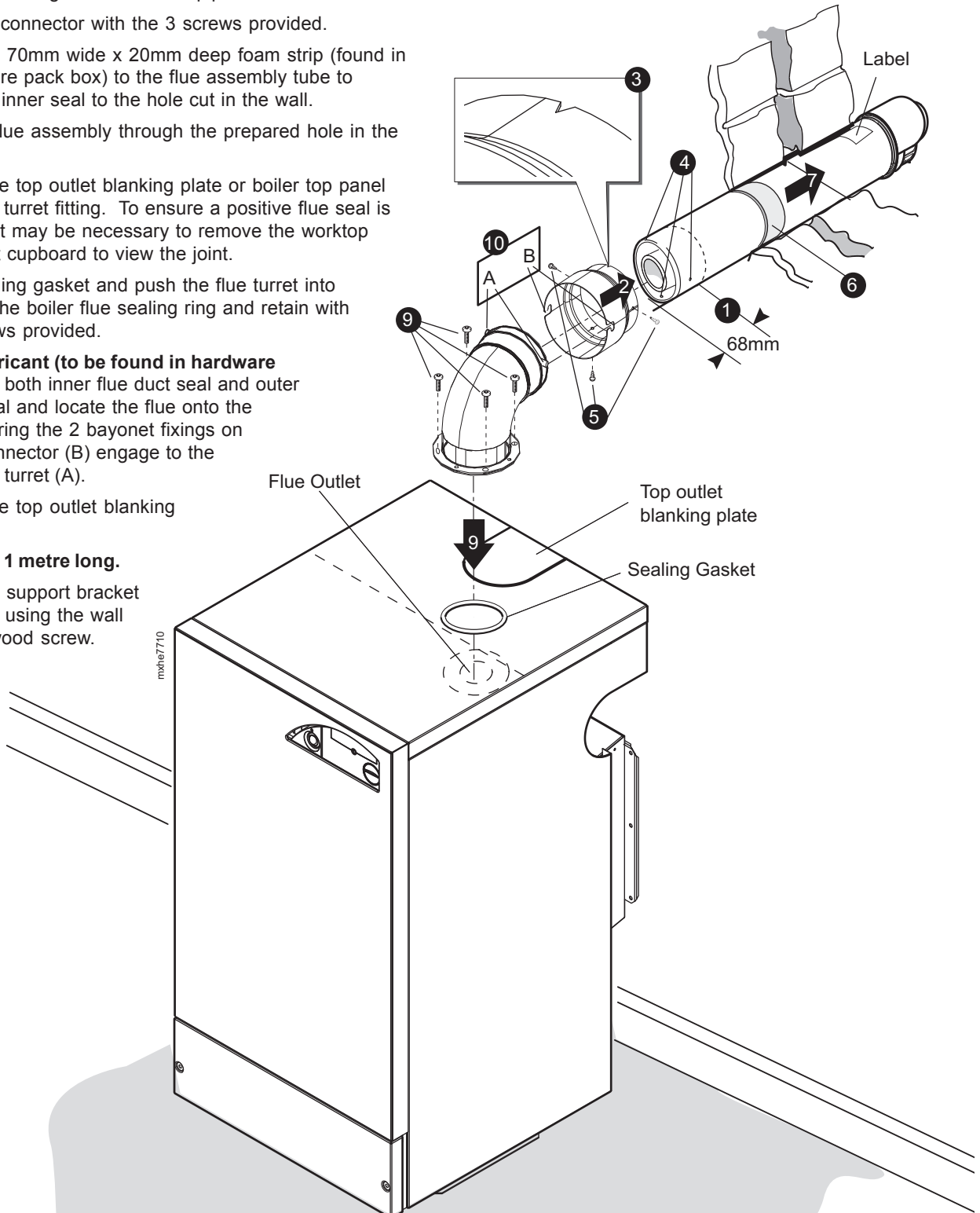

# INSTALLATION

## 29 FITTING THE OPTIONAL ROOF FLUE KIT (Flat or Pitched)

**Note.**

A flat or pitched roof flashing plate (not supplied) is required before proceeding with the installation of this kit.

This kit is suitable for both flat and pitched roof terminations, using a concentric flue to run vertically from the top of the boiler and terminating above roof level.

Connection to the top of the boiler is made using a separately supplied vertical connector

**WEATHER PROOFING**

Where the flue passes through the roof line an adequate seal must be made. This is achieved by using either:

Flat roof weather collar or Universal weather collar.

**ACCESSORIES**

Flue Duct Extension Kits are available for flue lengths extending beyond 1m. These packs contain 1m extension ducts and may be cut to the desired length.

If the offset vertical option is used an elbow Kit is required. For a full accessories list refer to page 7, Optional Extras.

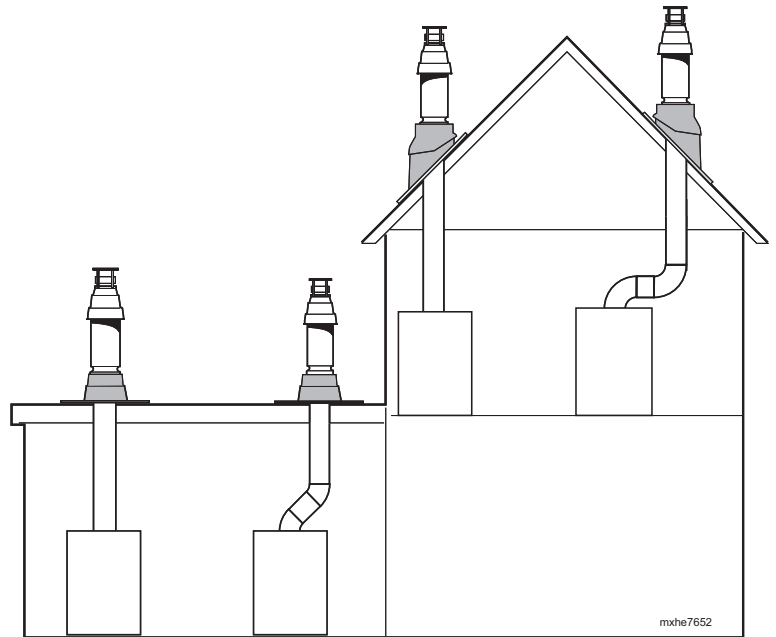

## 30 ROOF FLUE KIT CONTENTS / OPTIONS

**NOTE. ITEMS D, E, F, G AND H ARE NOT SUPPLIED WITH THE ROOF FLUE KIT.**

- A. Flue assembly with terminal
- B. Flue seal collar
- C. 3.5x13 screw
- D. Pitched roof tile/flat roof tile weather collar
- E. Vertical connector (60/100) comes with gasket and fixing screws
- F. Roof flue extension duct kit (60/100)
- G. 90° elbow kit (60/100)
- H. 45° elbow kit (60/100)

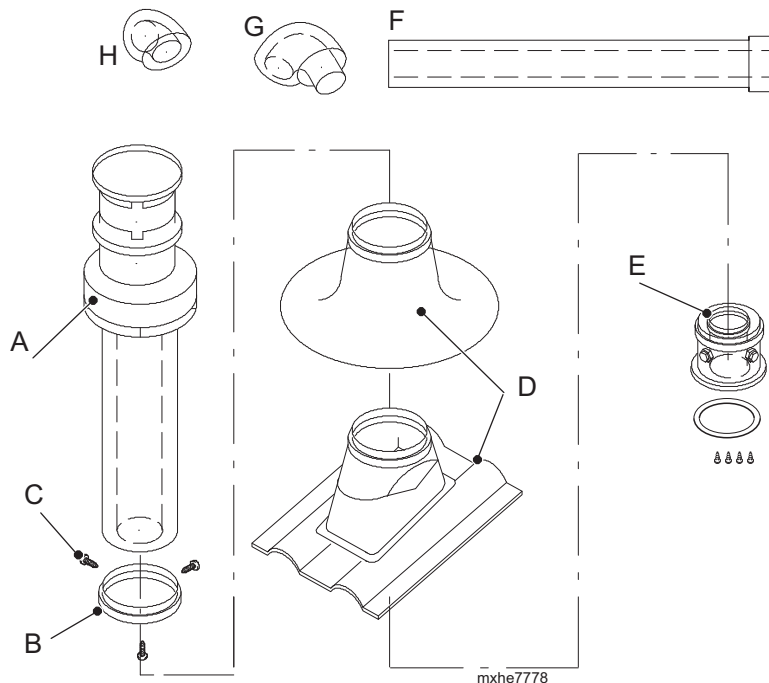

FLUE OUTLET

# INSTALLATION

## 31 FLUE TERMINAL POSITION

The terminal should be positioned so that products of combustion can safely disperse at all times.

**Plumbing may occur at the termination so, where possible, terminal positions where this could cause a nuisance should be avoided.**

Minimum dimensions are shown below

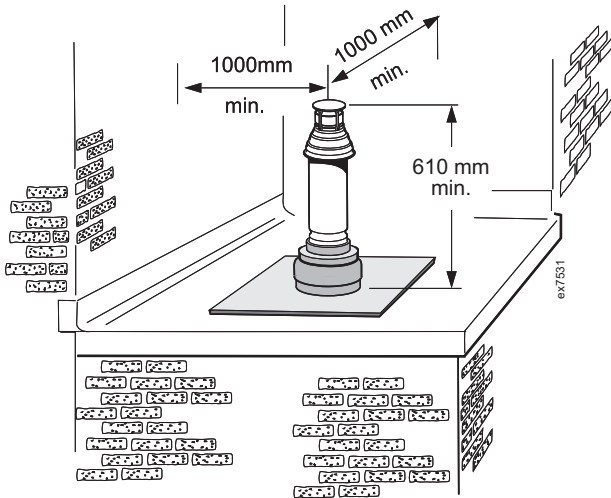

Flat roof - with structure

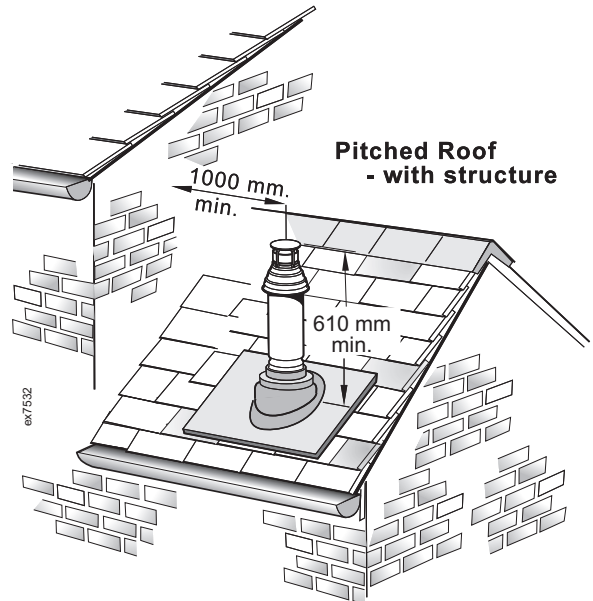

Pitched Roof - with structure

Terminal Position	Minimum Dimension
Directly below an opening, air brick, windows, etc.	300 mm
Below plastic / painted gutters	300 mm
Painted surface	300 mm
Below eaves or balcony	500 mm

## 32 FLUE ARRANGEMENT

Part No.	Description	60/100 Quantity				
		HE15	HE18	HE24	HE30	HE36
n/a	Maximum Flue Length (m)	8	8	8	5	5
201 180	Flue ext. 60/100	7	7	7	6	6
201 189	Terminal Vertical Roof 60/100	1	1	1	1	1
158 431	Weather Collar Pitched Roof	1	1	1	1	1
158 432	Weather Collar Flat Roof	1	1 </td <td>1</td> <td>1</td> <td>1</td>	1	1	1
201 182	90° Elbow Kit (60/100)	4	4	4	2	2
201 183	45° Elbow Kit (60/100)	4	4	4	2	2
201 869	Vertical Connector	1	1	1	1	1

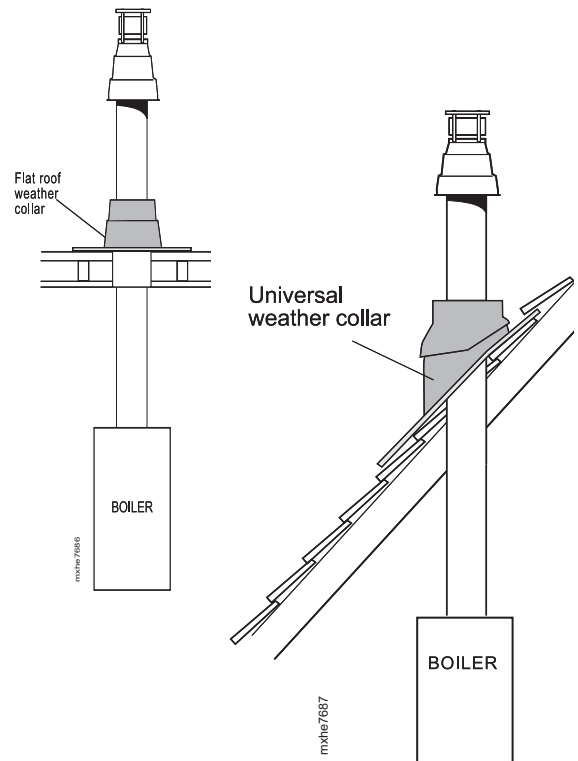

**Note.**

The equivalent flue length resistance of the 90° elbow kit (60/100) is 1m and the 45° elbow kit (60/100) is 0.75m.

# INSTALLATION

## 33 ASSEMBLING THE ROOF FLUE KIT

Determine the correct height that the flue should terminate above the roof. If after calculating or measuring the overall flue height from the top of the boiler, it is necessary to cut both pipes of assembly A, then ensure they are cut equally leaving the inner flue tube longer than the outer air tube as supplied. (Refer to No. 5 below)

Ensure the cut pipe ends are free from any burrs.

1. Ensure the flue seal collar B is located onto the flue assembly A.
2. Position the roof flashing plate D (supplied separately) over the hole cut in the roof and insert flue assembly A from the roof end.
3. Remove the casing top outlet blanking plate (2 screws) or boiler top panel to facilitate fitting the vertical connector. Fit the sealing gasket and push fit the vertical connector E (supplied separately) into the boiler flue connection and retain with the four securing screws provided.
4. "Push" fit extension duct F (if required, supplied separately) and the roof flue kit assembly A into the vertical connector E. Using the lubricant found in the hardware pack to facilitate fitting.
5. If the last extension duct requires cutting, measure the distance (outer ducts) between the duct and the terminal and add 100 mm to this dimension. This gives the length of the last extension duct.

**Note.** Check the position of the inner flue duct relative to the outer duct on the assembled extension duct(s) and ensure the terminal flue duct is cut longer than the air duct to ensure engagement in the final flue duct seal.

6. Slide down and position the flue seal collar B over the roof plate D and secure it with the 3 screws C to the flue assembly A.
7. Finally ensure the roof flashing plate D is correctly sealed to the roof.

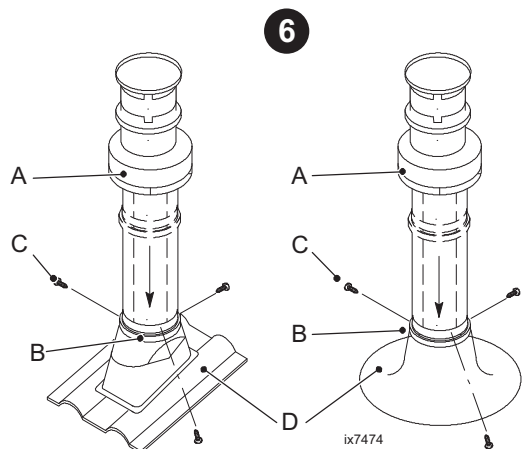
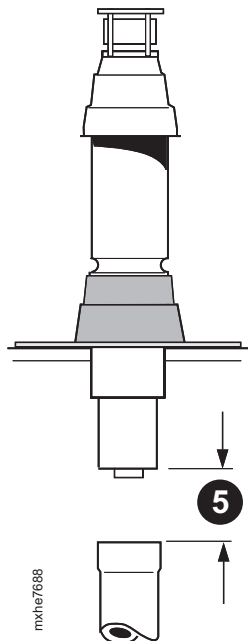
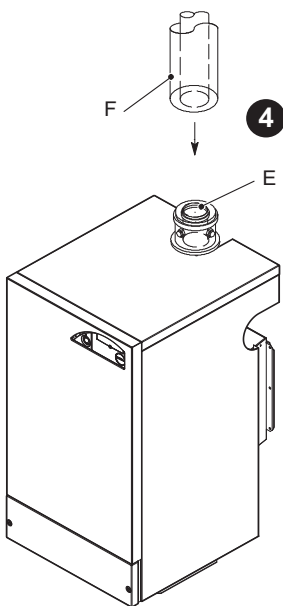
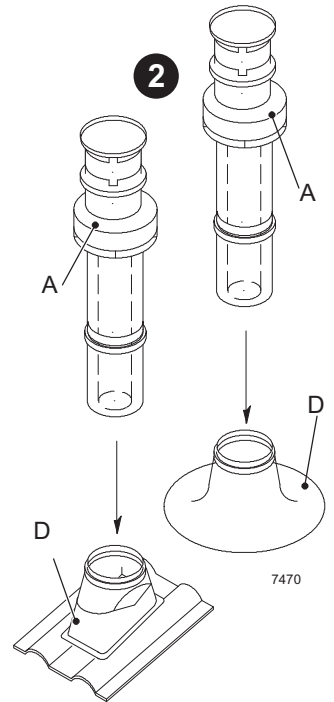
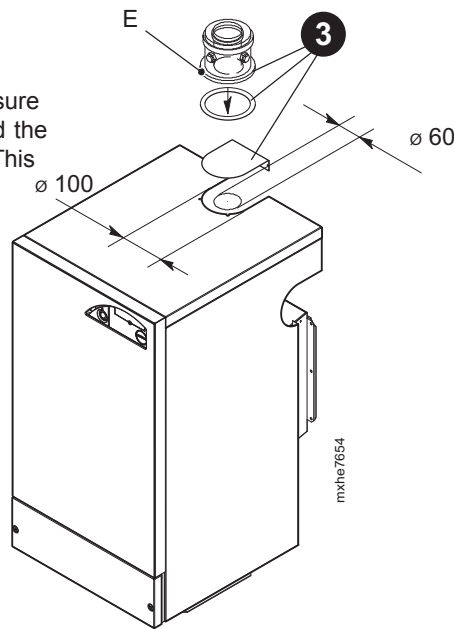
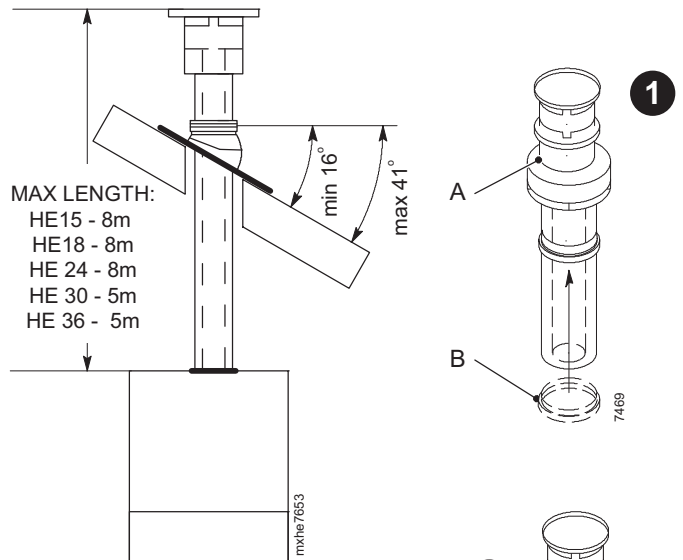

# INSTALLATION

## 34 ELECTRICAL CONNECTIONS

**WARNING.** This appliance MUST be earthed.

A mains supply of 230 V ~ 50 Hz is required.

All external controls and wiring MUST be suitable for mains voltage.

The fuse rating should be 3 A.

Wiring external to the boiler MUST be in accordance with the current I.E.E. (BS.7671) Wiring Regulations and any local regulations.

Wiring should be 3 core PVC insulated cable NOT LESS than 0.75 mm<sup>2</sup> (24 x 0.2mm) and to BS. 6500, Table 16.

For IE reference should be made to the current ETCI rules for electrical installations.

Connection must be made in a way that allows complete isolation of the electrical supply - such as a double pole switch having a 3mm (1/8") contact separation in both poles, or a plug and socket serving only the boiler and system controls. The means of isolation must be accessible to the user after installation.

## 35 INTERNAL WIRING

A pictorial wiring diagram is shown in Frame 36.

1. Route the mains cable, the condensate pump cable (if required) and the remote user controls wiring (if required) via the rear of the boiler and through the grommet situated at the back left of the appliance.
2. Wire a permanent live supply into the 5-way terminal strip L3, N and  $\perp$ .
3. Remove the red link and wire the switched live supply into L1 and L2.
4. Secure the mains lead with the cable clamp.

5. Remove condensate pump terminal strip securing screw to gain access to the terminal strip.
6. Route the condensate pump cable via the rear of the boiler and through the grommet situated at the back left of the appliance.
7. Wire live, neutral and earth into the 5 way condensate pump terminal strip.
8. Remove the red link and wire the two black wires into the terminals marked "C" and "NC"
9. Secure the mains lead with the cable clamp.

**ONLY IF USING THE OPTIONAL CONDENSATE PUMP THEN CONTINUE TO STEP 5.**

**MAINS TERMINAL STRIP**

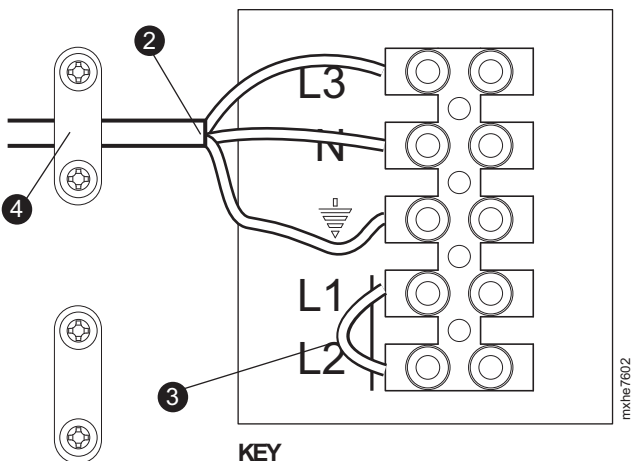

**KEY**  
 L3 - Permanent Live  
 L1 - Live Feed  
 L2 - Switched Live Input

**Note.**

Ensure that the lengths of the current carrying conductors are shorter than the earth conductor so that if the cable slips in its anchorage the current carrying conductors become taut before the earth conductor.

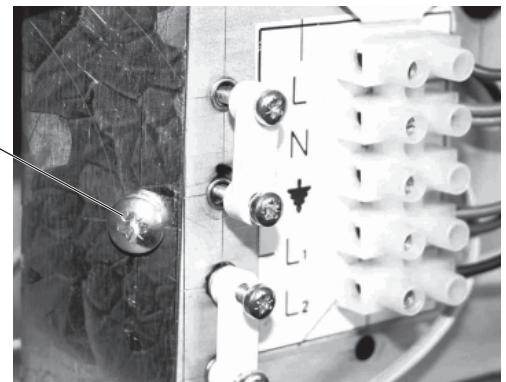

**CONDENSATE PUMP TERMINAL STRIP**

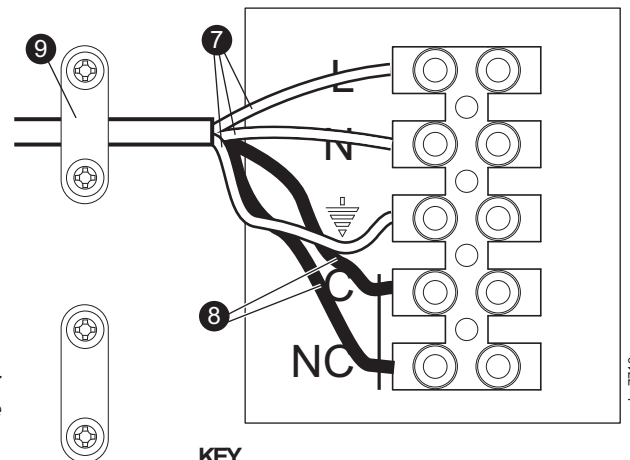

**KEY**  
 C - Alarm Common  
 NC - Alarm Normally Closed

# INSTALLATION

## 36 PICTORIAL WIRING DIAGRAM

- LEGEND**  
 b - blue  
 bk - black  
 br - brown  
 gy - grey  
 or - orange  
 pk - pink  
 r - red  
 v - violet  
 w - white  
 y - yellow  
 y/g - yellow/green

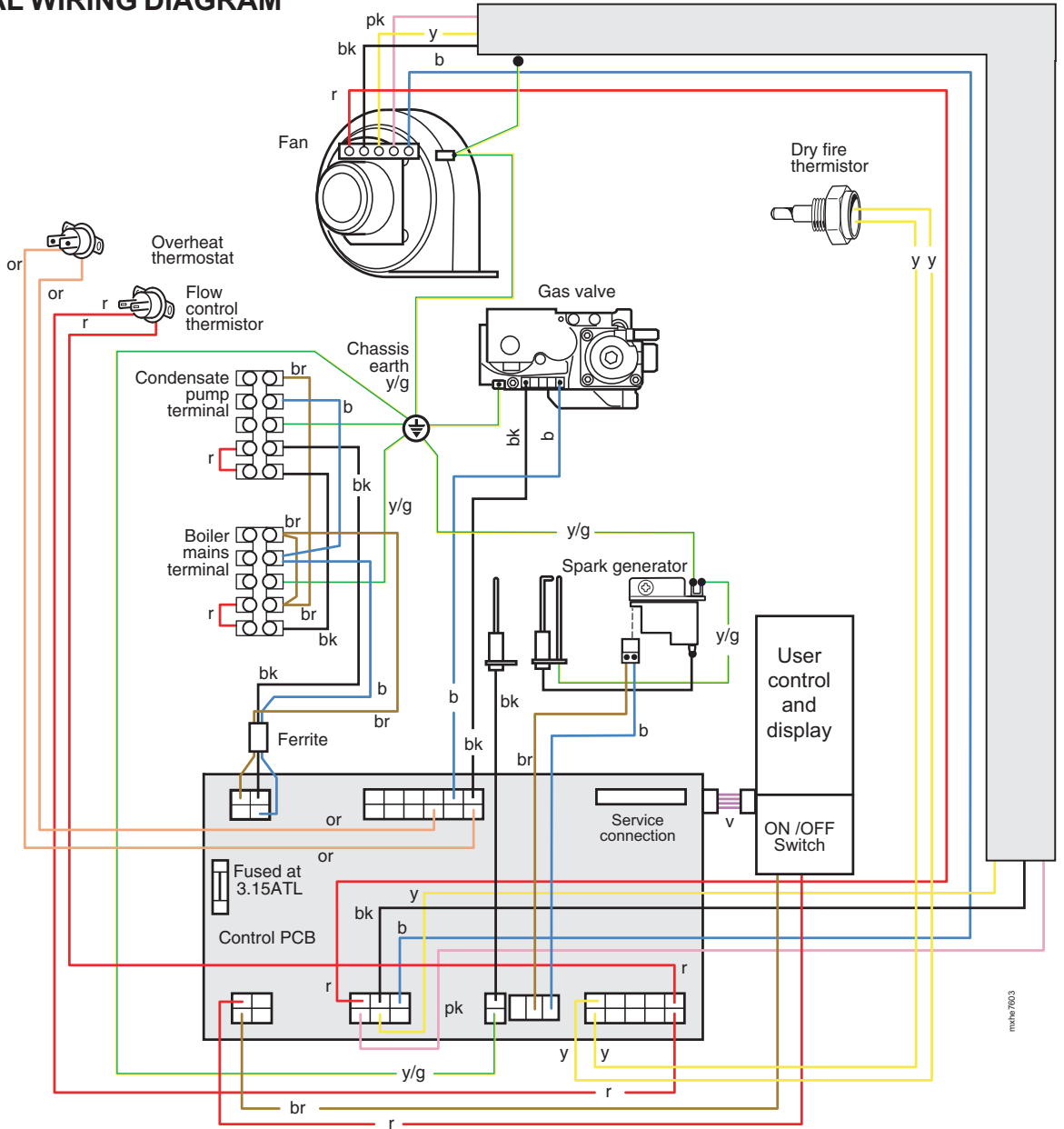

## 37 FUNCTIONAL FLOW WIRING DIAGRAM

- LEGEND**  
 b - blue  
 bk - black  
 br - brown  
 gy - grey  
 or - orange  
 pk - pink  
 r - red  
 v - violet  
 w - white  
 y - yellow  
 y/g - yellow/green

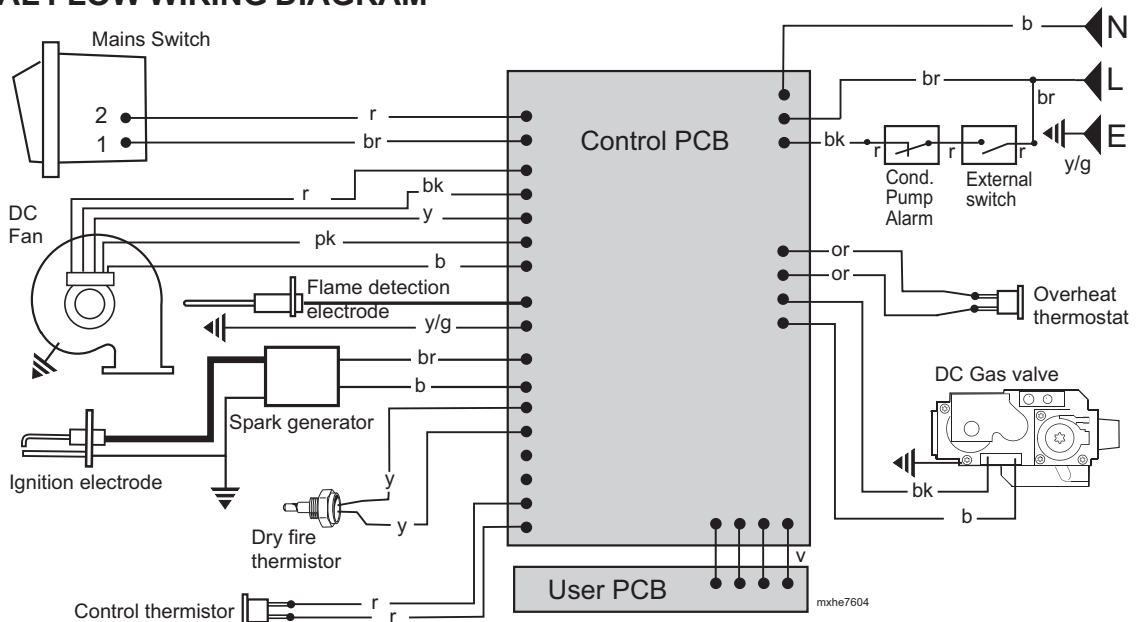



### 38 EXTERNAL ELECTRICAL CONTROLS

Wiring external to the boiler MUST be in accordance with the current I.E.E. (BS.7671) Wiring Regulations and any local regulations.

For IE reference should be made to the current ETCI rules for electrical installations.

The fuse should be 3A.

#### Room Thermostat

If the thermostat has a neutral connection use it. (It provides for more energy efficient operation by reducing switching temperature differentials.)

#### Frost Protection

If parts of the pipework run outside the house or if the boiler will be left off for more than a day or so then a frost thermostat should be wired into the system. This is usually done at the programmer, in which case the programmer selector switches are set to OFF and all other controls MUST be left in the running position.

The frost thermostat should be sited in a cold place but where it can sense heat from the system.

If the boiler is installed in a garage it may be necessary to fit a pipe thermostat, preferably on the return pipework.

**Important.** Ensure that the frost thermostat is wired so that the system pump and/or external diverter valve is energised, as appropriate.

Designation of the terminals will vary but the programmer and thermostat manufacturers' leaflets will give full details.

**Diagram A** shows an application to boilers fitted with a room thermostat only.

**Diagrams B and C** show applications to boilers fitted with alternative time controls.

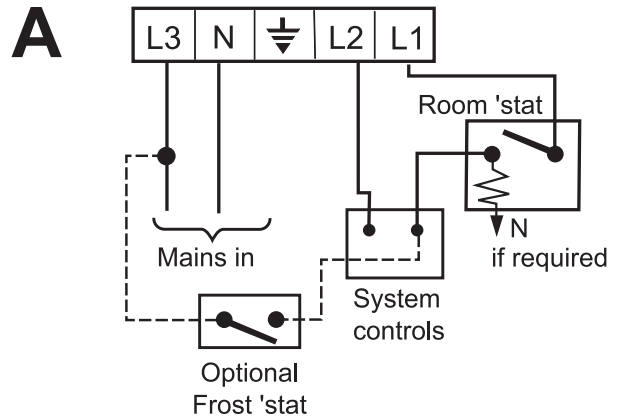

mxhe9221

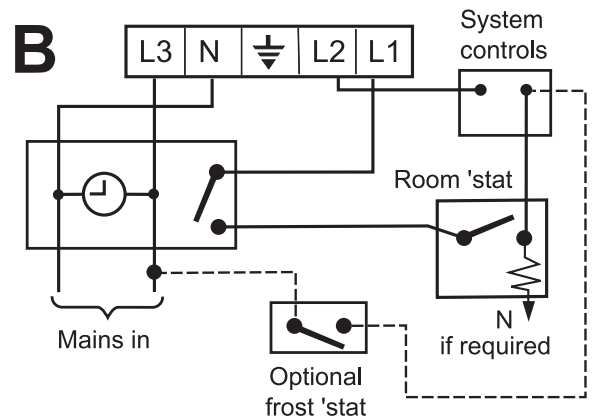

mxhe9222

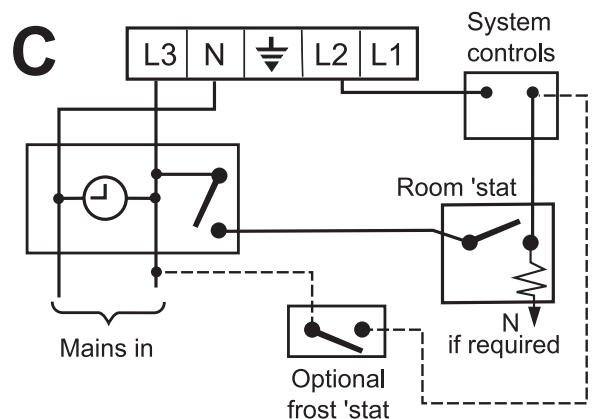

mxhe9223

**Earths are not shown for clarity but MUST NEVER BE OMITTED.**

### 39 COMMISSIONING AND TESTING

#### A. ELECTRICAL INSTALLATION

1. Checks to ensure electrical safety should be carried out by a competent person.
2. ALWAYS carry out the preliminary electrical system checks, i.e. earth continuity, polarity, resistance to earth and short circuit, using a suitable test meter.

#### B. GAS INSTALLATION

1. The whole of the gas installation, including the meter, should be inspected and tested for soundness and purged in accordance with the recommendations of BS. 6891. In IE refer to I.S. 813:2002.
2. Purge air from the gas installation by the approved methods only.

**WARNING.** Whilst effecting the required gas soundness test and purging air from the gas installation, open all windows and doors, extinguish naked lights and DO NOT SMOKE.



# INSTALLATION

## 40 INITIAL LIGHTING

1. Check that the system has been filled and that the boiler is not air locked.  
**Note.** *It is important the burner is not operated before the system is fully vented of air. If it is necessary to operate the system pump to assist venting of the air this must be done with the gas service cock turned off.*
2. Check that all drain cocks are closed and any valves in the flow and return are open.
3. Check the electrical supply is off.
4. Check the gas service cock is open.
5. Check that the boiler on/off switch (A) is OFF
6. Slacken the screw in the inlet pressure test point (G) and connect a gas pressure gauge via a flexible tube.
7. Switch the electricity supply ON and check all external controls are calling for heat.
8. Set the boiler thermostat knob (B) to maximum and switch the boiler on/off switch (A) to ON. The boiler control should now go through its ignition sequence until the burner is established.
9. If the boiler does not light after 3 attempts the fault codes L 'F' will be displayed. Press the reset button (C); the boiler will then repeat its ignition sequence. When the burner is established the WHITE burner ON neon (D) will be permanently illuminated.

### LEGEND

- A On/Off switch
- B CH Thermostat knob
- C Reset button
- D Burner On Neon
- E Display
- F Injector pressure test point
- G Inlet pressure test point
- H Gas service cock

10. Ensure that with the boiler operating the dynamic gas pressure is able to obtain maximum output.

**N.B.** The principle of the 1:1 gas valve ensures that the **mexico HE** range is able to deliver their full output at inlet pressures down to 14mb. However if dynamic pressures below 20mb are experienced ensure this is adequate for **ALL** other gas appliances in the property.

### IMPORTANT.

**The gas input to the burner is regulated by the gas valve according to the air flow produced by the fan. It is NOT user-adjustable. Any interference to sealed settings on the gas valve will adversely affect operation and render our warranty void.**

11. Switch OFF the boiler on/off switch.
12. Remove the pressure gauge and tube. Tighten the sealing screw in pressure test point. Ensure a gas tight seal is made.
13. Refit the boiler front panel.

### THE DISPLAY

The user control has one neon and one display to inform the user about the status: the display will show the status of the boiler and the neon will show the status of the flame. If no flame is detected the neon is blinking. When the flame is detected the neon will be lit permanently.

Below is a list with display function in normal operation.

- D** Standby. No demand for heat present.
- C** Boiler is active for central heating or domestic hot water.
- H** Boiler is in lockout for a specific error. The display will be blinking, alternating with a number or letter to show which error is detected.
- L** Boiler is in lockout for a specific error. The display will be blinking, alternating with a number or letter to show which error is detected.
- P** Boiler frost protection. Boiler will fire when temperature is less than 3 degrees.

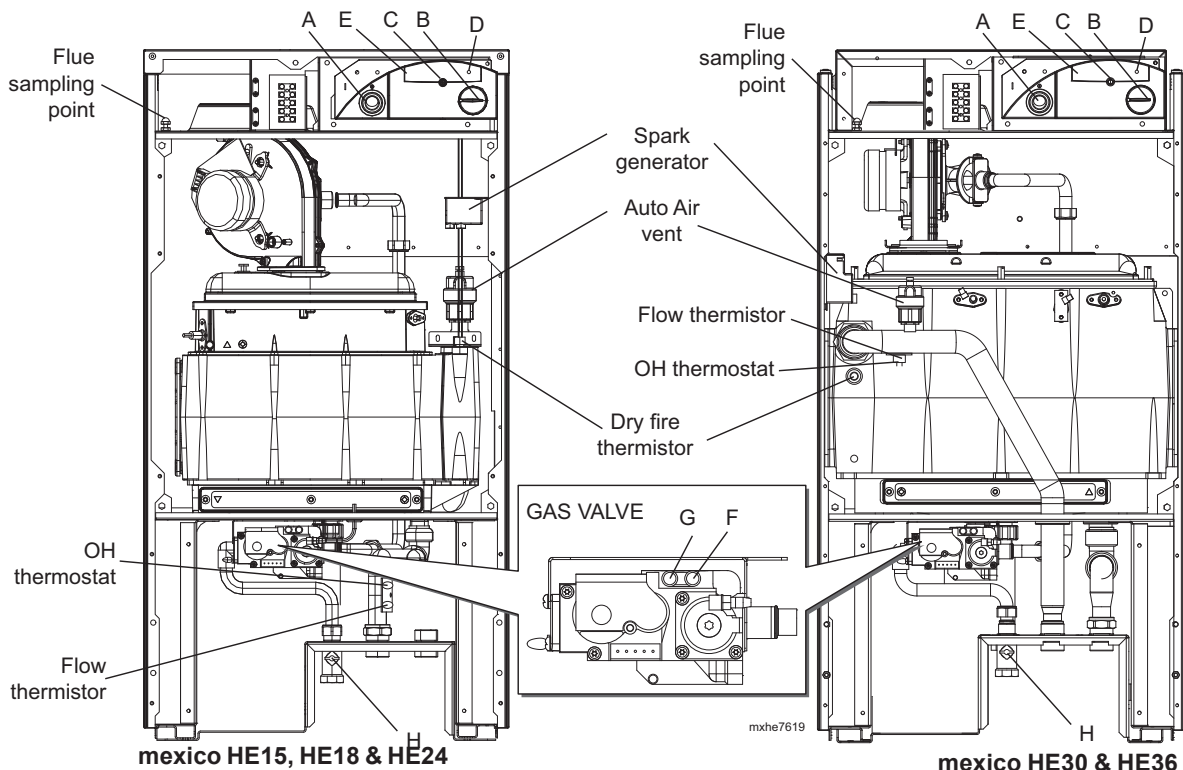

# INSTALLATION

## 4.1 GENERAL CHECKS

Make the following checks for correct operation:

### 1. Central Heating

The correct operation of ANY programmer and all other system controls should be proved. Operate each control separately and check that the main burner or circulating pump, as the case may be, responds. Ensure the external controls are calling for heat. After ignition the display should read:

c  - white neon on

### 2. Gas Rate

Operate the boiler for 10 minutes. Check the boiler gas rate (see Table 2), ensuring the boiler is at full output whilst measurements are recorded.

### 3. Water Circulation System

Knob Setting	Flow Temperature	
	°C	°F
Min	30	86
Max	82	180

**Note.** *Fernox Superfloc, Sentinel X300 (new systems) / X400 (existing systems) or Salamander products flushing solutions should be used during the flushing procedure. Refer to Frame 9.*

- a. With the system HOT examine all water connections for soundness.
  - b. With the system still HOT, turn off the gas, water and electricity supplies to the boiler and drain down to complete the flushing process.
  - c. Refill and vent the system, add inhibitor (see Frame 9), clear all air locks and again check for water soundness. Adhere the water treatment warning label, supplied in the hardware pack, in a *prominent position* on the system, to prevent the use of incorrect water treatment additives.
  - d. Balance the system. Refer to Frame 4.
4. Check the condensate drain for leaks and check that it is discharging correctly
  5. Finally set the controls to the user's requirements.
- The temperatures quoted alongside are approximate, and vary between installations.

## 4.2 HANDING OVER

After completing the installation and commissioning of the system the installer should hand over to the householder by the following actions:

1. Hand the Installation / User's Instructions to the householder and explain his or her responsibilities under current Gas Safety (Installation and Use) Regulations or rules in force.
2. Explain and demonstrate the lighting and shutting down procedures.
3. The operation of the boiler and the use and adjustment of ALL system controls should be fully explained to the householder to ensure the greatest possible fuel economy consistent with household requirements of both heating and hot water consumption. Advise the User of the precautions necessary to prevent damage to the system and to the building in the event of the system remaining inoperative during frosty conditions.
4. Explain the function and the use of the boiler heating controls.
5. Explain the function of the boiler fault mode. Emphasise that if a fault is indicated the boiler should be turned off and a CORGI registered installer consulted. In IE contact a competent person.
6. Explain and demonstrate the function of time and temperature controls, radiator valves, etc., for the economic use of the system.
7. If any programmer is fitted then draw attention to the Programmer User's Instructions and hand them to the householder.
8. **After installation and commissioning please complete the *benchmark* Commissioning Checklist before handover to the customer. For IE, it is necessary to complete a "Declaration of Conformity" to indicate compliance to I.S. 813:2002.**
9. **IMPORTANT**  
Stress the importance of regular servicing by a CORGI registered installer and that a comprehensive service should be carried out AT LEAST ONCE A YEAR. In IE servicing work must be carried out by a competent person.
10. As the installer you may wish to undertake the service contract yourself or alternatively offer to the customer the benefits of the Ideal Care Scheme, details of which are outlined in the household pack supplied with this boiler.

## 43 SERVICING SCHEDULE

To ensure the continued safe and efficient operation of the appliance it is recommended that it is checked at regular intervals and serviced as necessary. The frequency of servicing will depend upon the installation condition and usage but should be carried out annually. It is the law that any service work must be carried out by a CORGI registered installer. In IE service work must be carried out by a competent person.

1. Light the boiler and carry out a pre-service check, noting any operational faults.
2. Check the gas consumption.
3. Connect a suitable gas analyser to the sampling point on top of the boiler or into the flue terminal, if access is possible. Refer to Frame 44.

For correct boiler operation the CO/CO<sub>2</sub> ratio of the flue gas should not be greater than 0.004 ratio. If this is the case, and the gas input is at least 90% of the nominal, once compliance with the note above is ensured, then no further action need be taken. If not, proceed to step 4 .

4. Clean the main burner.
5. Clean the heat exchanger and 'S' trap.
6. Check the condition of the combustion chamber insulation. Any cracked or damaged pieces should be replaced (HE15, HE18 and HE24 only).
7. Check the main injector for blockage or damage.

8. Wherever possible, remove and clean the condensate 'S' trap (refer to Frame 48) and check the drain for blockage.
9. Check that the flue terminal is unobstructed and that the flue system is sealed correctly.
10. If fitted, clean the condensate pump.

The servicing procedures are covered more fully in Frames 46 to 50 and MUST be carried out in sequence.

**Note.** In order to carry out either servicing or replacement of components the boiler front panels, and sealing panel must be removed. Refer to Frames 44 and 45.

### WARNING.

Always turn off the gas supply at the gas service cock, and switch off and disconnect the electricity supply to the appliance before servicing.

### IMPORTANT.

11. After completing the servicing or exchange of components always test for gas soundness and carry out functional checks as in paragraphs 2 and 3.
12. When work is complete the sealing panel MUST be correctly refitted, ensuring that a good seal is made.

**DO NOT OPERATE THE BOILER IF THE SEALING PANEL IS NOT FITTED.**

13. Complete the service section of the Benchmark Commissioning Checklist.

## 44 BOILER FRONT PANEL REMOVAL

1. Remove the two screws retaining the lower front panel and remove the panel.
2. Remove the two screws retaining the upper front panel.
3. Lift the upper front panel and remove.

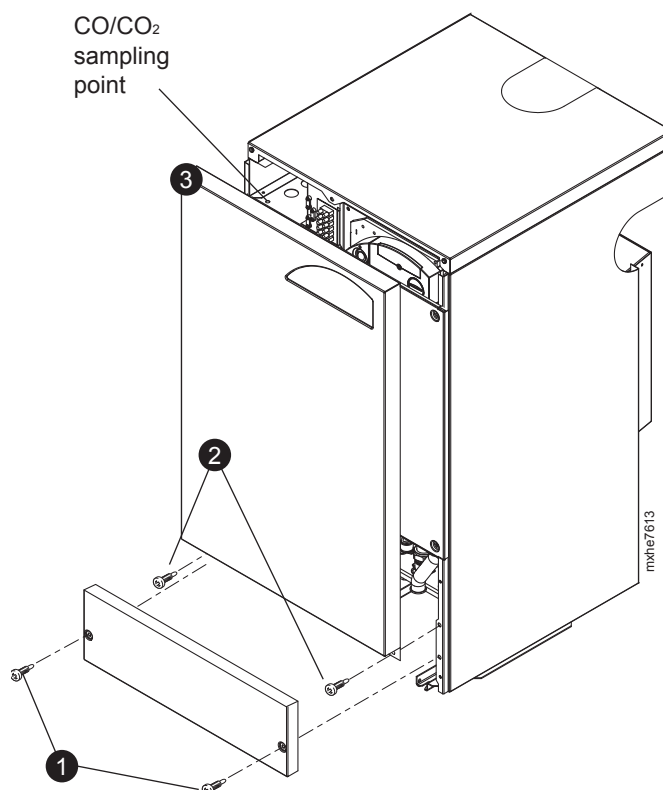

## 45 BOILER SEALING PANEL REMOVAL

1. To remove the sealing panel remove the 4 screws.
2. Remove the panel.

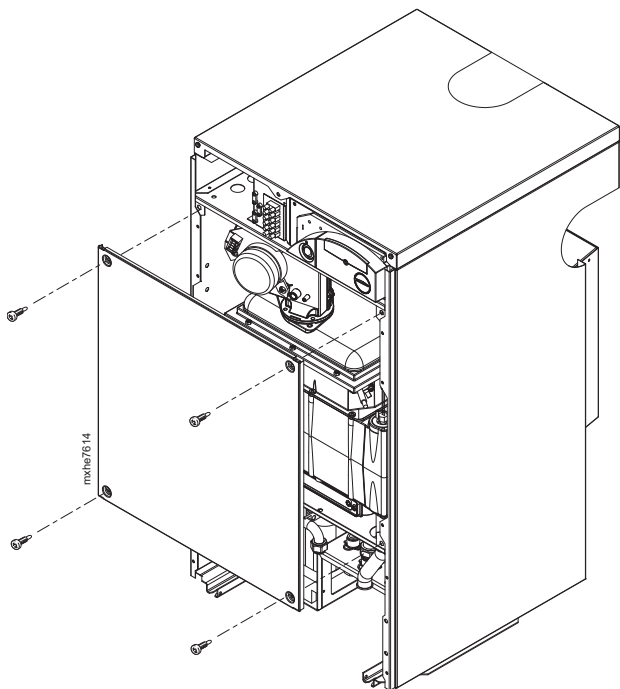

## 46 FAN AND VENTURI ASSEMBLY REMOVAL AND CLEANING

1. Undo the gas pipe union connection to the injector housing.
2. Undo the screw on the fan mounting bracket.
3. Lift off the fan and venturi assembly.
4. Disconnect the electrical leads from the fan.
5. Inspect the injector for blockage or damage.

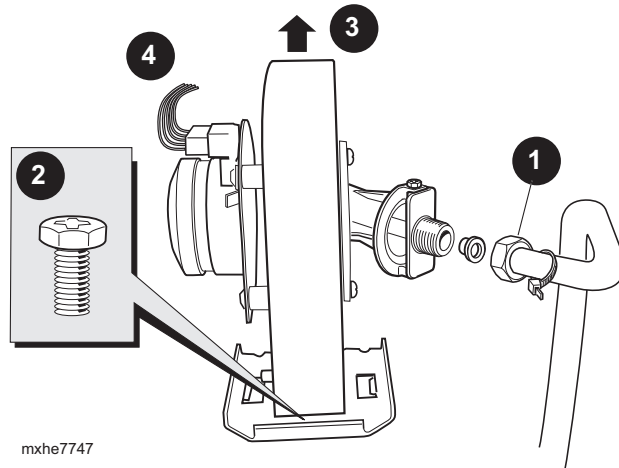

## 47 BURNER REMOVAL AND CLEANING

1. Remove the 6 fixings securing the burner (the 3 screws at the rear are extended to ease access).
2. Lift off the burner from the combustion chamber.

### IMPORTANT

The burner head is a ceramic plaque construction. Care must be taken to ensure that **the burner is not placed down upon its face** as this may cause damage to the ceramic.

3. Brush off any deposits that may be on the ceramic with a SOFT brush.
4. Inspect the sealing gasket around the burner and combustion chamber insulation for any signs of damage. Replace as necessary.

### Note.

Take care not to disturb the ionisation probes at the front and rear of the combustion chamber.

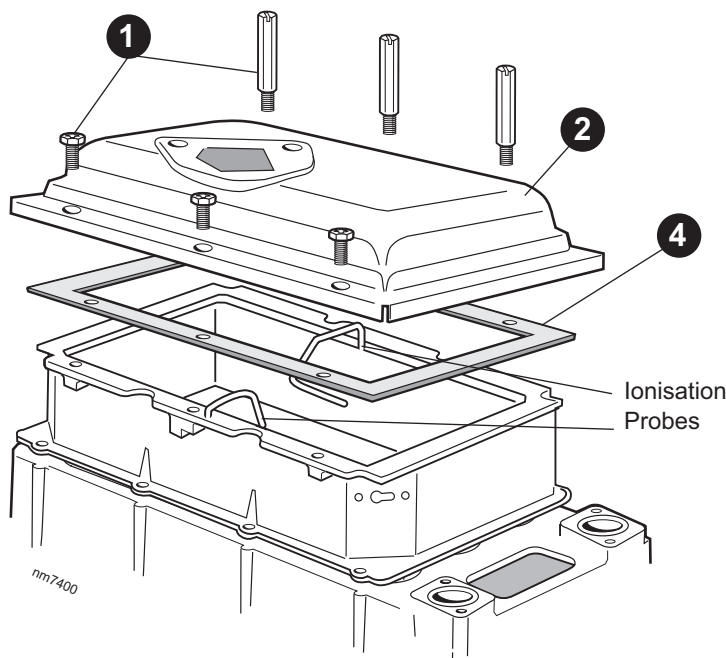

mexico HE 24 shown

## SERVICING

### 48 CLEANING THE CONDENSATE 'S' TRAP & CONDENSATE PUMP (IF FITTED)

If condensate pump fitted refer to separate instructions for cleaning procedure.

1. If a condensate pump is fitted, it must be removed and pulled forward to gain access to the condensate 'S' trap. Refer to Frame 69.

Note. Care must be taken with residual water when removing the outlet pipe.

2. Remove the plastic union sealing nut on the bottom of the condensate 'S' trap.
3. Remove and clean from the cartridge and ball any residual deposits.
4. Inspect the opaque 'S' trap for further signs of dirt and clean as necessary.
5. Replace the cartridge and ball and replace the plastic sealing nut.
6. Replace the condensate pump.



### 49 CLEANING THE HEAT EXCHANGER

1. Remove ignition and flame detection electrodes. Refer to Frames 55 and 56.
2. Remove the 3 screws retaining the sump cover and remove.
3. Using a suitable tool clean the exposed heat exchanger fins through the sump cover. Also vacuum any debris from the top of the heat exchanger.
4. Remove any loose deposits from the sump.
5. Inspect the ignition and detection electrodes. Ensure that they are clean and in good condition - replace if necessary.
6. Check the condition of the combustion chamber insulation (HE15, 18 and 24 only). Any cracked or damaged pieces must be replaced.

**Note.** Take care not to disturb the ionisation probes at the front and rear of the combustion chamber.

7. Check that the ignition and detection gaps are correct. Refer to Frames 55 and 56.

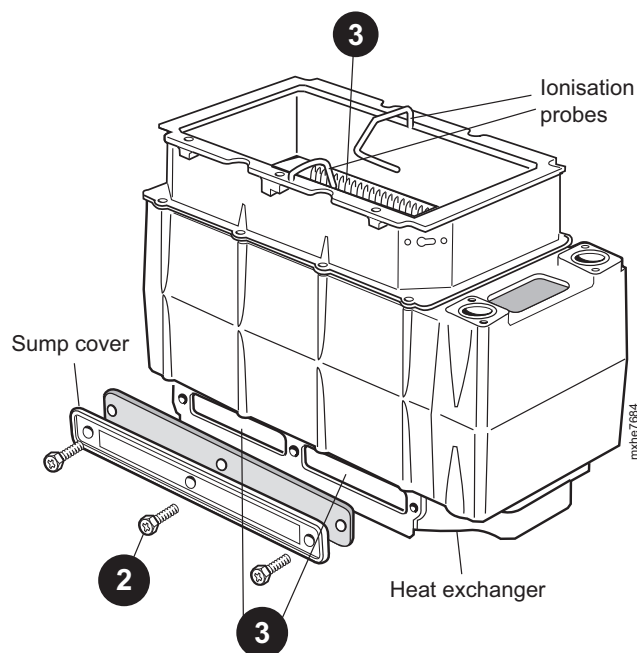

### 50 REASSEMBLY

Reassemble the boiler in the following order.

1. Refit the sump cover plate.
2. Refit the electrodes (check dimensions Frames 55 and 56).
3. Refit the burner.
4. Refit the fan / venturi assembly.
5. Reconnect the fan electrical leads.

6. Refit the boiler sealing panel.

#### IMPORTANT.

Ensure the boiler sealing panel is correctly fitted and that a good seal is made.

7. Refit the boiler front panels.
8. Turn on the gas supply at the gas service cock.
9. Reconnect the electrical supply.



## 51 REPLACEMENT OF COMPONENTS

### GENERAL

When replacing ANY component:

1. Isolate the electricity supply.
2. Turn off the gas supply.
3. Remove the boiler front panels and inner sealing panel. Refer to Frames 44 and 45.

After replacing ANY component check operation of the boiler including gas soundness, gas rate and combustion test.

### IMPORTANT

When work is complete, the sealing panel must be correctly fitted, ensuring that a good seal is made.

### Note.

In order to assist fault finding, the control panel has an LED diagnostic display. The key to boiler fault conditions is shown in Frame 70.

**THE BOILER MUST NOT BE OPERATED WITHOUT THE SEALING PANEL FITTED**

## 52 FLOW THERMISTOR REPLACEMENT

1. Refer to Frame 51.
2. Remove the boiler front panels and inner sealing panel. Refer to Frames 44 and 45.
 

**Note.** Only the boiler front panels need removing on the HE15, 18 and 24 models)
3. Pull the electrical leads off the flow thermistor and remove earth connection.
4. Remove the two screws retaining the flow thermistor.
5. Replace flow thermistor retaining with the fixing screws previously removed and reconnect leads.
6. Reassemble the boiler in reverse order.
7. Check the operation of the boiler. Refer to Frame 51.

mexico HE15, HE18 & HE24

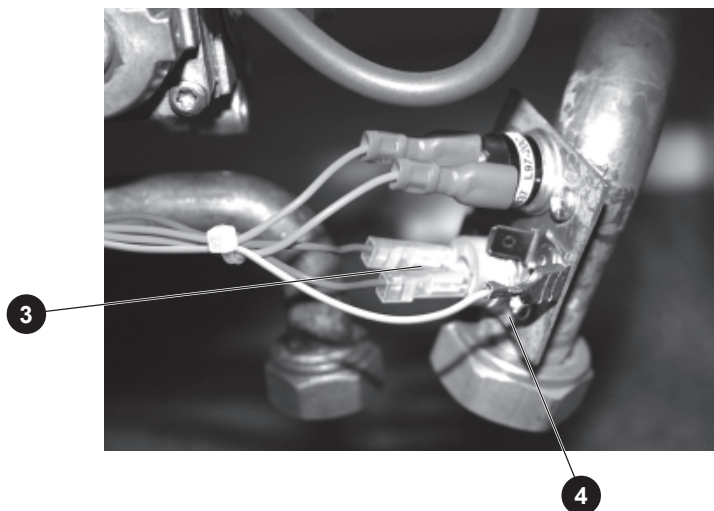

mexico HE30 & HE36

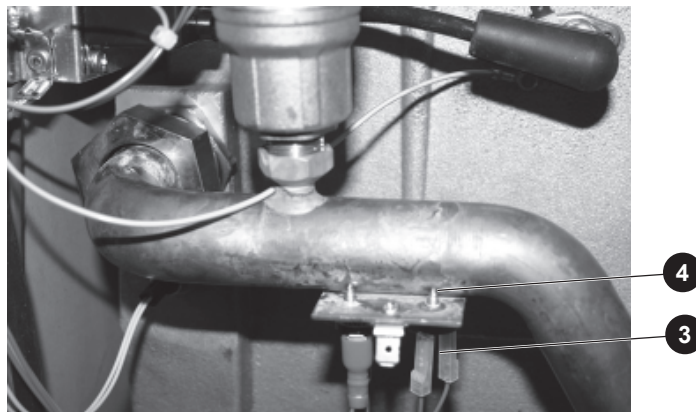

## 53 FAN REPLACEMENT

1. Refer to Frame 51.
2. Remove the boiler front panels and inner sealing panel. Refer to Frames 44 and 45.
3. Unscrew the gas pipe union connection to the injector housing.
4. Unscrew and remove the screw retaining the fan mounting bracket.
5. Remove the fan and venturi assembly.
6. Disconnect the electrical leads from the fan.
7. Remove the 3 screws and remove the venturi assembly, *noting the orientation of the venturi in relation to the fan body.*
8. Transfer the venturi assembly to the new fan, replacing the gasket if evidence of damage or deterioration is visible.
9. Fit the new fan / venturi assembly.
10. Reassemble the boiler in reverse order, taking care not to over tighten the screw on the fan mounting bracket.
11. Check the operation of the boiler. Refer to Frame 51.

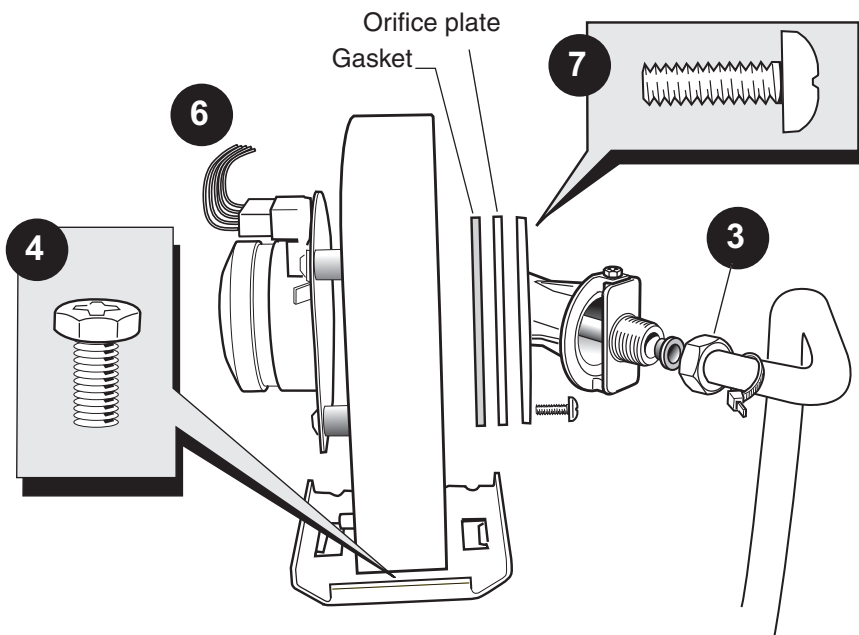

## 54 BURNER REPLACEMENT

1. Refer to Frame 51.
2. Remove the boiler front panels and inner sealing panel. Refer to Frames 44 and 45.
3. Remove the fan assembly. Refer to Frame 53 (no's 3 to 6.)
4. Remove the 6 fixings securing the burner (the 3 screws at the rear are extended to ease access).
5. Lift off the burner from the combustion chamber.
6. Fit the new burner, replacing any damaged or deteriorating sealing gasket.
7. Reassemble in reverse order.
8. Check the operation of the boiler. Refer to Frame 51.

**Note.** *Take care not to disturb the burner earth pins at the front and rear of the combustion chamber. (burner earth pins are at the front only on the HE30 and HE36)*

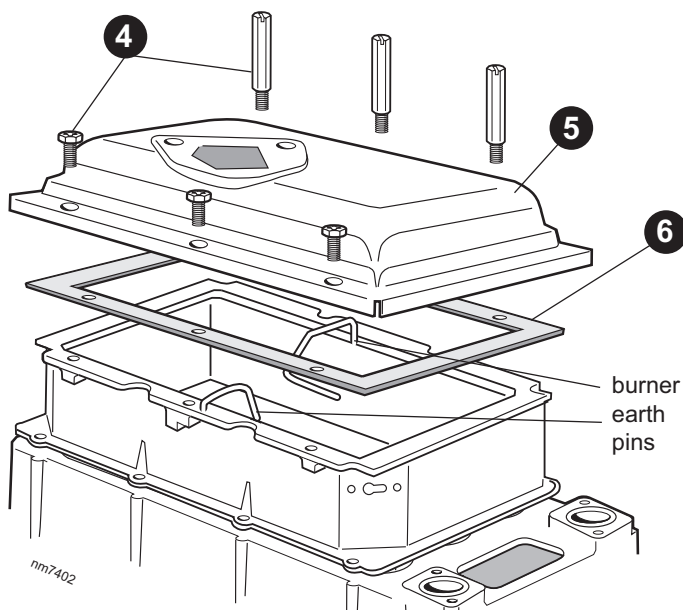

HE24 shown



## 55 IGNITION ELECTRODE REPLACEMENT

1. Refer to Frame 51.
2. Remove the boiler front panels and inner sealing panel. Refer to Frames 44 and 45.
3. Unplug the ignition lead from the electrode.
4. Remove the burner. Refer to Frame 54.
5. Remove the earth lead from the ignition electrode.
6. Remove the remaining screw holding the ignition electrode to the combustion chamber.
7. Remove the electrode.
8. Fit the new ignition electrode, using the new gasket supplied. Check dimensions as shown.
9. Reassemble in reverse order and check that no damage to the combustion chamber insulation has occurred during the electrode replacement. (HE15, HE18 and HE24 only)
10. Check operation of the boiler. Refer to Frame 51.

Spark gap 3.5mm

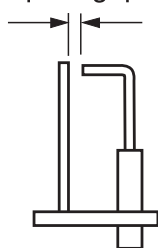

8mm ± 1 (HE15, HE18, HE24)  
15mm ± 1 (HE30, HE36)

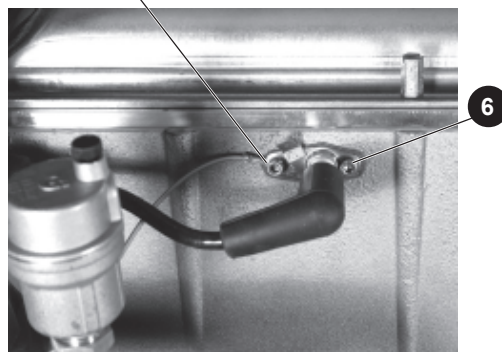
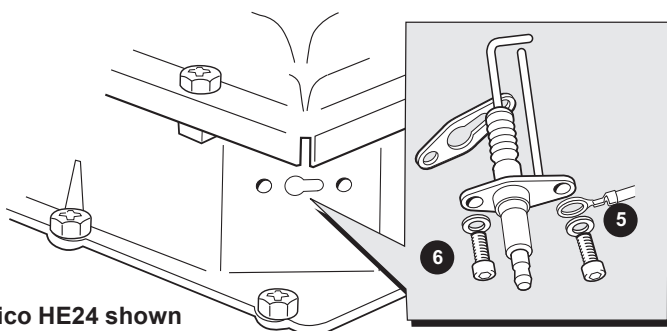
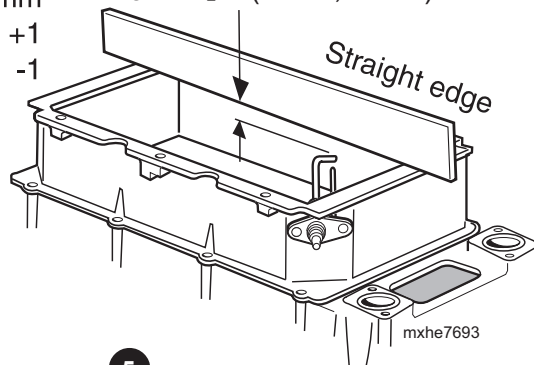

## 56 FLAME DETECTION ELECTRODE REPLACEMENT

1. Refer to Frame 51.
2. Remove the boiler front panels and inner sealing panel. Refer to Frames 44 and 45.
3. Unplug the flame detection lead from the electrode.
4. Remove the burner. Refer to Frame 54.
5. Remove the 2 screws holding the flame detection electrode to the combustion chamber.
6. Remove the flame detection electrode.
7. Fit the new flame detection electrode, using the new gasket supplied. Check dimension as shown.
8. Reassemble in reverse order and check that no damage to the combustion chamber insulation has occurred during the electrode replacement. (HE15, HE18 and HE24 only).
9. Check operation of the boiler. Refer to Frame 51.

22mm ± 1 (HE15, HE18, HE24)  
16mm ± 1 (HE30, HE36)

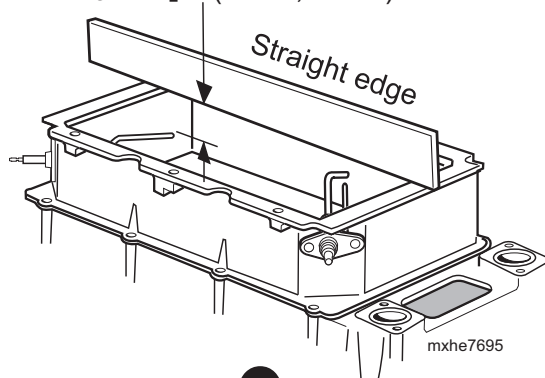

mexico HE24 shown

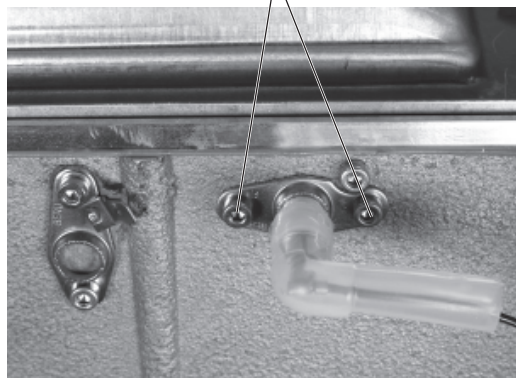
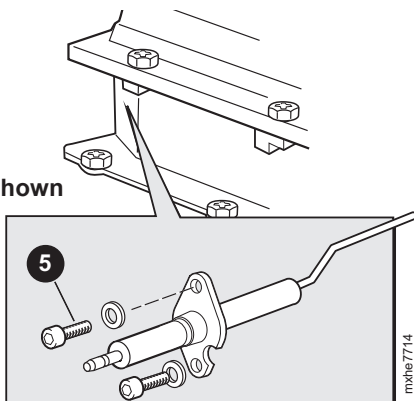

mexico HE30 and HE36 shown

## SERVICING

### 57 SPARK GENERATOR REPLACEMENT

1. Refer to Frame 51.
2. Remove the boiler front panels and inner sealing panel. Refer to Frames 44 and 45.
3. Disconnect the leads from the spark generator and bracket.
4. Remove the 2 M4 screws securing the spark generator to the bracket.
5. Fit the new spark generator and re-assemble in reverse order.
6. Check operation of the boiler. Refer to Frame 51.

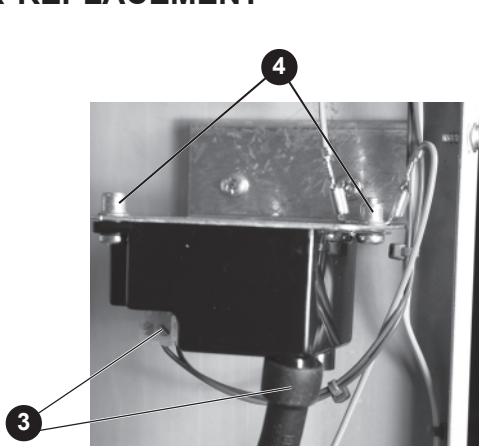

mexico HE15, HE18 and HE24

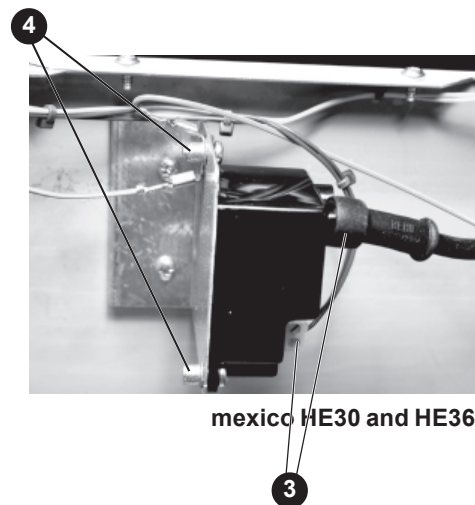

mexico HE30 and HE36

### 58 BURNER INJECTOR REPLACEMENT

1. Refer to Frame 51.
2. Remove the boiler front panels and inner sealing panel. Refer to Frames 44 and 45.
3. Remove the fan / venturi assembly. Refer to Frame 53.
4. Remove the 2 injector housing screws.
6. Withdraw the injector housing.
7. Fit the new injector housing, complete with injector.
8. Reassemble in reverse order, ensuring that the new gas seal supplied is located correctly in the injector housing.
9. Check operation of the boiler. Refer to Frame 51.

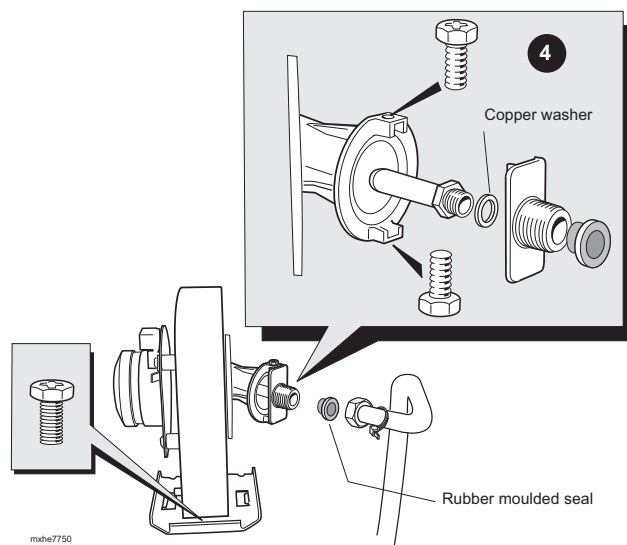

mxhe7750

### 59 GAS CONTROL VALVE REPLACEMENT

1. Refer to Frame 51.
2. Remove the boiler front panels and inner sealing panel. Refer to Frames 44 and 45.
3. Unplug the electrical lead from the gas control valve and disconnect the earth wire.
4. Undo the sensing tube connection at the gas control valve.
5. Undo the union nut at the gas valve pre-piping frame connection.
6. Undo the union nut on the outlet side of the gas control valve and remove valve.
7. Undo the 4 gas valve bracket screws, bracket and gas inlet pipe and remove.
8. Remove the valve bracket fixing screw.
9. Transfer the mounting bracket and gas inlet pipe to the new gas control valve.
10. Fit new gas control valve, ensuring that any seals showing damage or deterioration are replaced.
11. Reassemble in reverse order.
12. Ensure the sensing tubing is correctly replaced.
13. Check operation of the boiler. Refer to Frame 51.

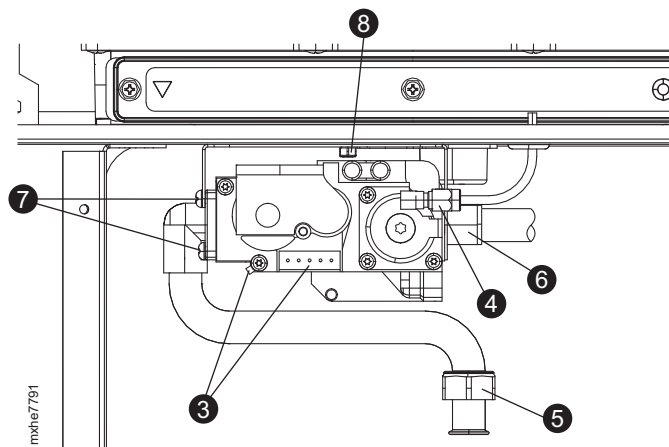

mxhe7791

### 60 CONTROL BOX REPLACEMENT

1. Refer to Frame 51.
2. Remove the boiler upper front panel. Refer to Frame 44.
3. Remove the 2 control box mounting bracket screws.
4. Pull the control box forward. Carefully unplug all the electrical wiring from the control box.
5. To remove the user control from the assembly pull the control forward to disconnect the plug.
6. Transfer the mounting brackets to the new control box.
7. Reassemble in reverse order.
8. Check operation of the boiler. Refer to Frame 51.

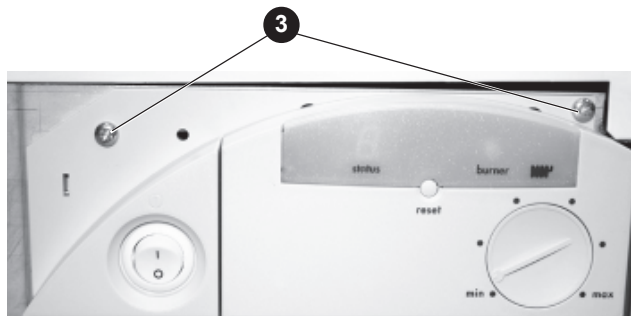

**N.B. To change the user control only.**

9. Loosen the screw on the underside of the user control.
10. Pull the display unit forward to remove.
11. Push the new display unit into position.
12. Reassemble in reverse order.
13. Check the operation of the boiler. Refer to Frame 51.

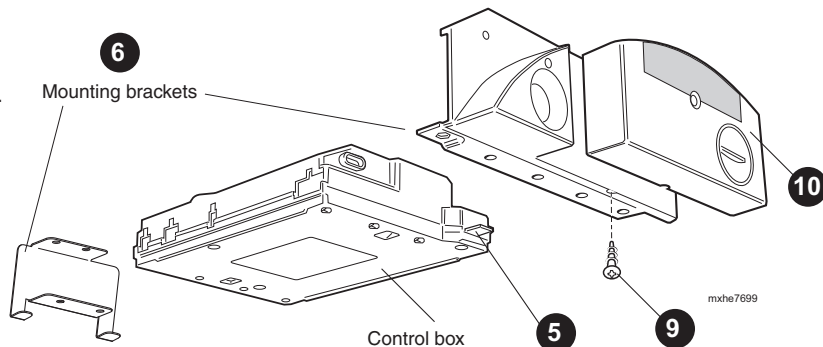

### 61 WIRING HARNESS REPLACEMENT

A pictorial wiring diagram is shown in Frame 36.

1. Refer to frame 51
2. Remove the boiler upper front panel. Refer to frame 44
3. Remove the sealing panel. Refer to frame 45
4. Disconnect the wiring harness from the Fan, Controls Box, Flow Thermistor, Spark Generator, Gas Valve, Overheat Thermistor, Dry Fire Thermistor, and Earth post.
5. Remove the condensate pump terminal strip securing screw to gain access to the back of the terminal strips.
6. With an Allan key remove the 'rivscrew' from the back of the brackets to release the terminal block.
7. Reassemble the new harness to the brackets in reverse order.

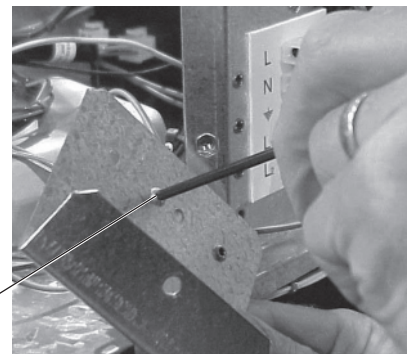
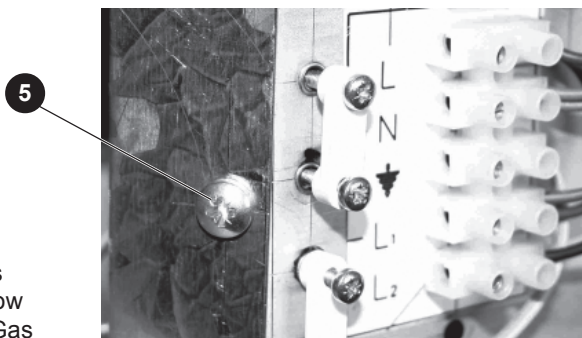

### 62 MAINS SWITCH REPLACEMENT

1. Refer to Frame 51.
2. Remove the boiler upper front panel. Refer to Frame 44.
3. Remove the screws retaining the user control. Refer to Frame 60, No. 3.
4. Push out the mains switch from the rear, as shown.
5. Refit the new switch, ensuring that the electrical leads are replaced on the correct terminals and the key on the switch is correctly aligned with the slot in the plastic moulding.
6. Reassemble in reverse order.
7. Check operation of the boiler. Refer to Frame 51.





## SERVICING

### 63 OVERHEAT THERMOSTAT REPLACEMENT

1. Refer to Frame 51.
2. Remove the boiler front panels and inner sealing panel (HE30 and HE36 only). Refer to Frames 44 and 45.
3. Pull off the 2 electrical leads from the thermostat body.
4. Remove the 2 screws retaining the O/H thermostat.
5. Fit the new thermostat, and reconnect leads
6. Reassemble in reverse order.
7. Check operation of the boiler. Refer to Frame 51.

mexico HE15, HE18 & HE24

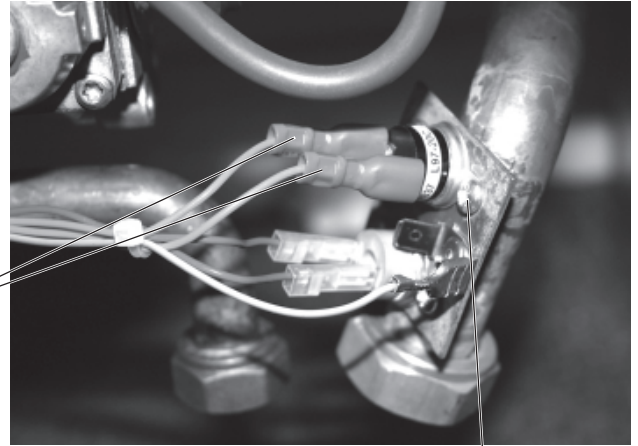

mexico HE30 & HE36

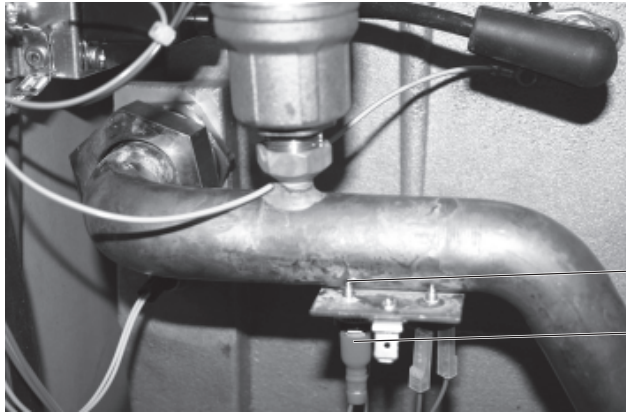

### 64 DRY FIRE THERMISTOR REPLACEMENT

1. Refer to Frame 51.
2. Remove the boiler front panels and inner sealing panel. Refer to Frames 44 and 45.
3. Drain down the system.
4. Pull off the electrical connection.
5. Unscrew and withdraw the thermistor.
6. Fit the new thermistor, using the gasket supplied.
7. Reassemble in reverse order.
8. Check operation of the boiler. Refer to Frame 51.

mexico HE30 & HE36



mexico HE15, HE18 & HE24

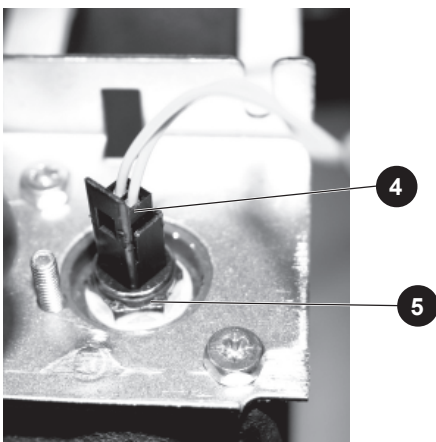

## 65 COMBUSTION CHAMBER INSULATION REPLACEMENT (HE15, HE18 and HE24 only)

The insulation boards used in the combustion chamber of this product are made of high temperature glass fibres with a binder of organic and inorganic materials.

Ideal Stelrad Group recommend that, for your own comfort and safety and to comply with good working practice, the procedure described below is followed:

1. Refer to Frame 51.
2. Remove the boiler front panels and inner sealing panel. Refer to Frames 44 and 45.
3. Remove the fan / venturi assembly. Refer to Frame 46.
4. Remove the burner. Refer to Frame 47.
5. Remove the ignition electrode. Refer to Frame 55.
6. Remove the flame detection electrode. Refer to Frame 56.
7. Remove the front and rear burner earth pins.

**Prior to removal of the board the following protective equipment should be worn:**

- **Face mask supplied with the spare part.**
  - **Glove supplied with the spare part.**
8. Damp down the combustion chamber area containing the insulation boards.
  9. Remove the split pin and washer from the RHS of the combustion chamber.

10. Remove the insulation boards. The replacement boards are supplied in a plastic bag. This bag should be retained and the discarded boards should now be placed into it.

11. Sweep any dampened particles and place in the plastic bag.

12. Fit new insulation boards.

**Note.**

*The boards are designed to be interlocking and should be fitted as shown.*

13. Fit the new split pin and washer in the RH of the chamber.

14. Remove the glove and face mask and place them in the plastic bag.

15. Wash your hands and any areas of skin which may have come into contact with any of the particles from the insulation board.

**Note.**

*Seal the plastic bag and dispose of it and its contents into a commercial tip.*

16. Reassemble in reverse order, remembering to re-fit the burner earth pins first.

17. Check operation of the boiler. Refer to Frame 51.

**Fit insulation in the following order:**

1. Rear
2. Left hand side
3. Front
4. Right hand side

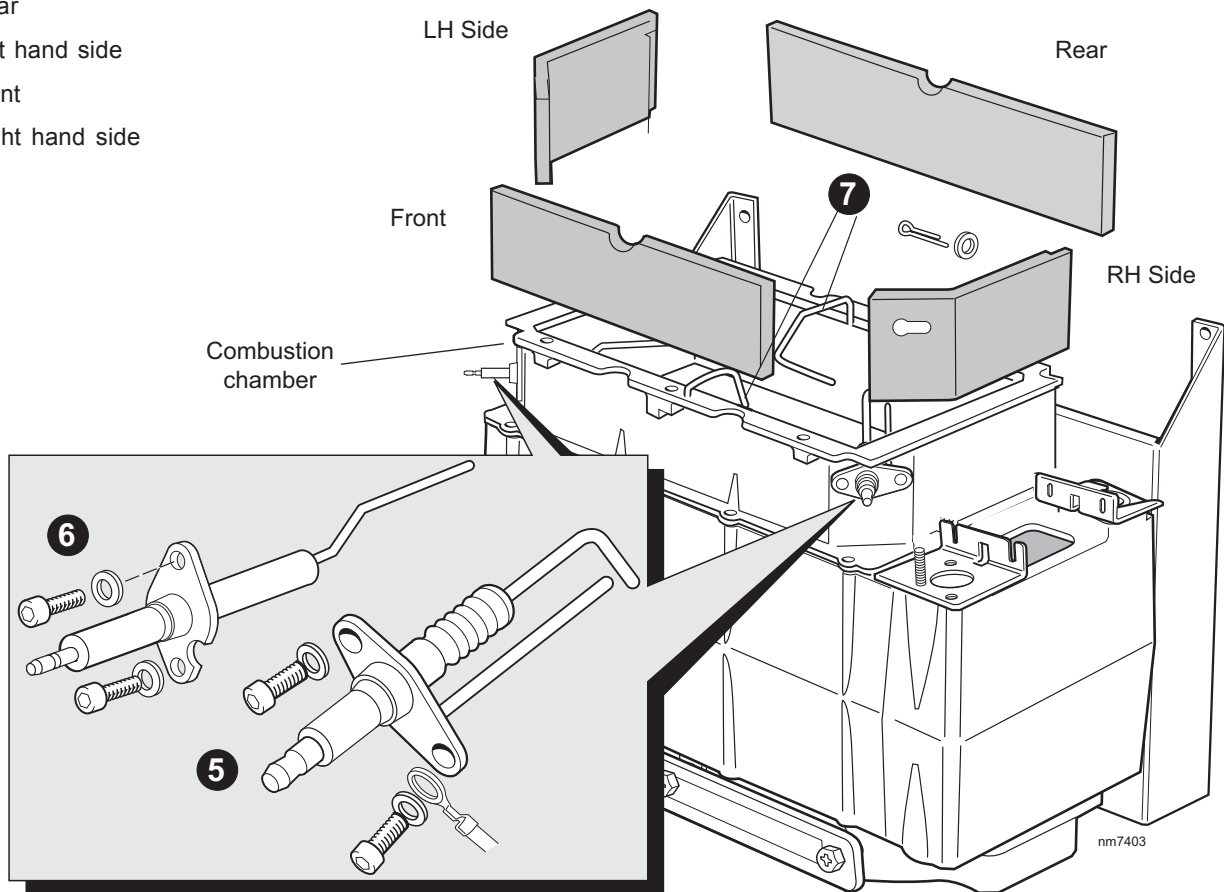

## 66 HEAT EXCHANGER REPLACEMENT

Refer also to Frame 10, 'Boiler exploded view'.

1. Refer to Frame 51.
2. Remove boiler front panels and inner sealing panel refer frames 44 & 45.
3. Remove the outer wall sealing plate (if fitted) and turn the terminal anticlockwise to unlock the turret bayonet fixing and pull the terminal to disconnect the boiler turret from the flue assembly.
4. Fully drain the system
5. Disconnect the gas, water flow & water return union connections at the pre-piping frame
6. Disconnect the condensate connection at the 'S' trap and the condensate pump (if fitted)
7. Protect the floor area front of the boiler, remove the screws fixing the boiler to the pre-piping frame and pull the boiler forward to clear any kitchen unit obstructions taking care with the electrical wiring.
8. Remove the fan & venturi assembly (refer to frame 46)
9. Remove burner (refer to frame 47)
10. Remove ignition electrode (frame 55) & detection electrode (frame 56)
11. HE30 & HE36 models only – Remove the spark generator (frame 57) and remove the electrical connections from the flow thermistor (frame 52 and the overheat thermostat (frame 63)
12. Remove the dry fire thermostat (frame 64)
13. HE15, 18 & 24 only – Remove the rubber plug to gain screwdriver access to the fixing screw retaining the heat exchanger bottom right copper pipe bracket and remove the screw.
14. HE30 & 36 only – Unscrew the copper pipe connection at the top left of the heat exchanger and remove the pipe by pulling upwards through the rubber grommet.
15. Remove the 4 screws retaining the flue turret and remove the turret.
16. Remove the 4 screws retaining the flue support bracket.
17. Remove the 19 screws retaining the rear air box and remove the box.
18. HE15, 18 & 24 only- Pull the flue elbow bracket slightly sideways to release the elbow and pull the plastic flue elbow assembly from its joint.
19. HE30 & 36 only- Pull the plastic pipe from its joint.

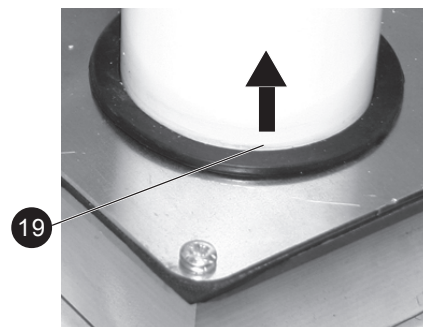
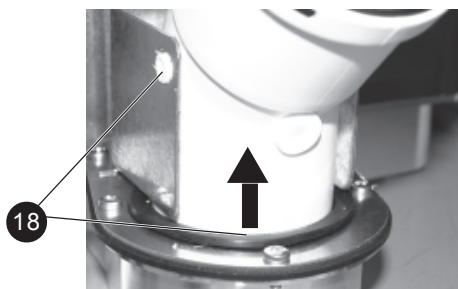
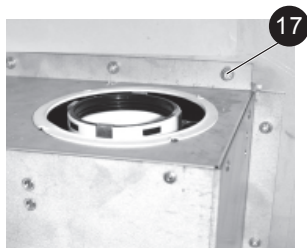
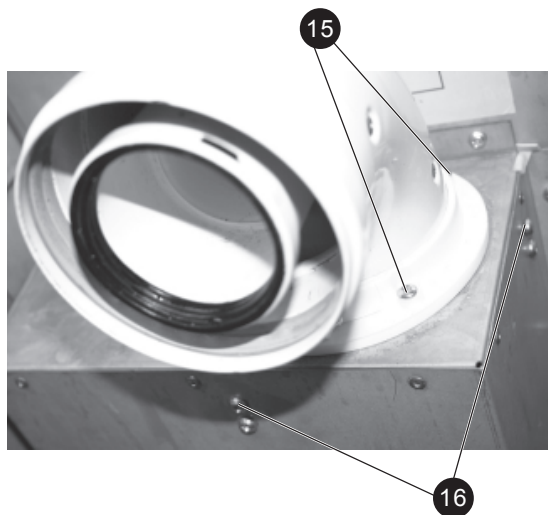
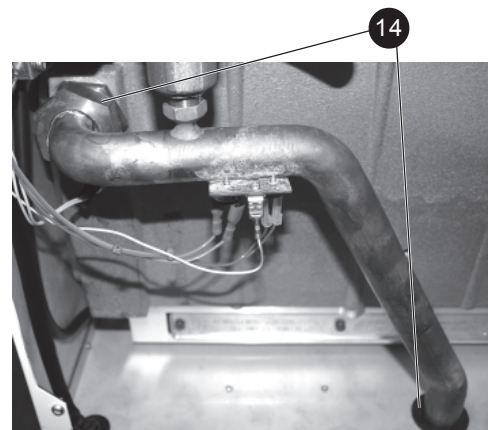
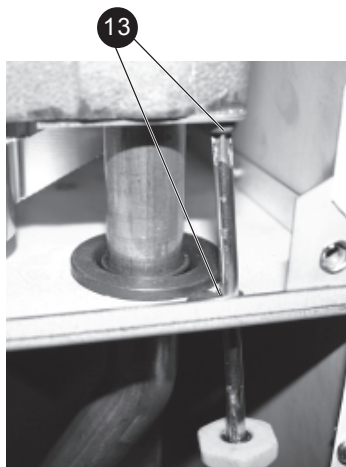

continued . . . .



## 67 HEAT EXCHANGER REPLACEMENT . . .continued

- 20. HE15, 18 & 24 only- Unscrew the 5mm hex. Hd. Screw retaining the copper pipe retention plate and remove plate.
- 21. HE30 & 36 only - Unscrew the return connection union.

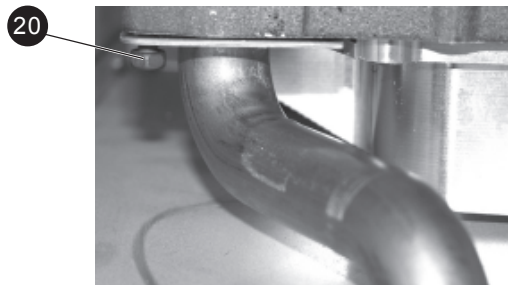

- 22. Remove the 5 screws retaining the sump.
- 23. Remove the 'S' trap bracket fixing screw and remove the 'S' trap.
- 24. Lift the heat exchanger to clear the bottom panel, pull forward and remove.
- 25. Fit the new heat exchanger, reassembling in reverse order, replacing gaskets or seals if any sign of damage or deterioration is evident. To ensure a positive flue seal is confirmed it may be necessary to remove the worktop or adjacent cupboard to view the joint.
- 26. Check the operation of the boiler. Refer to frame 51.

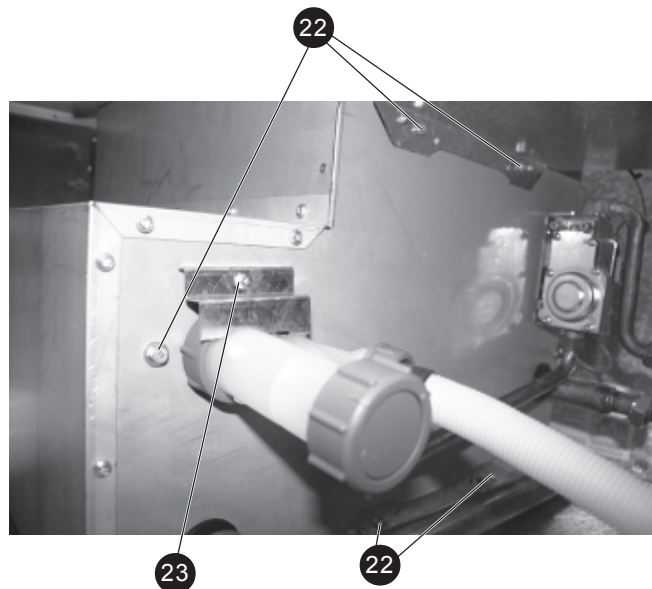

## 68 INNER SEALING PANEL SEAL REPLACEMENT

- 1. Refer Frame 51.
- 2. Remove the boiler front panels and refer to Frame 44.
- 3. Remove the inner sealing panel. Refer to Frame 45.
- 4. Remove the old seal from the panel and thoroughly clean the panel surfaces.
- 5. Fit the new adhesive seals - note that they are supplied to the correct length for the relevant sides.
- 6. Reassemble in reverse order.

**Note.**  
Ensure that the boiler sealing panel is correctly seated, compressing the seal to make an airtight joint.

- 7. Check operation of boiler. Refer to Frame 51.

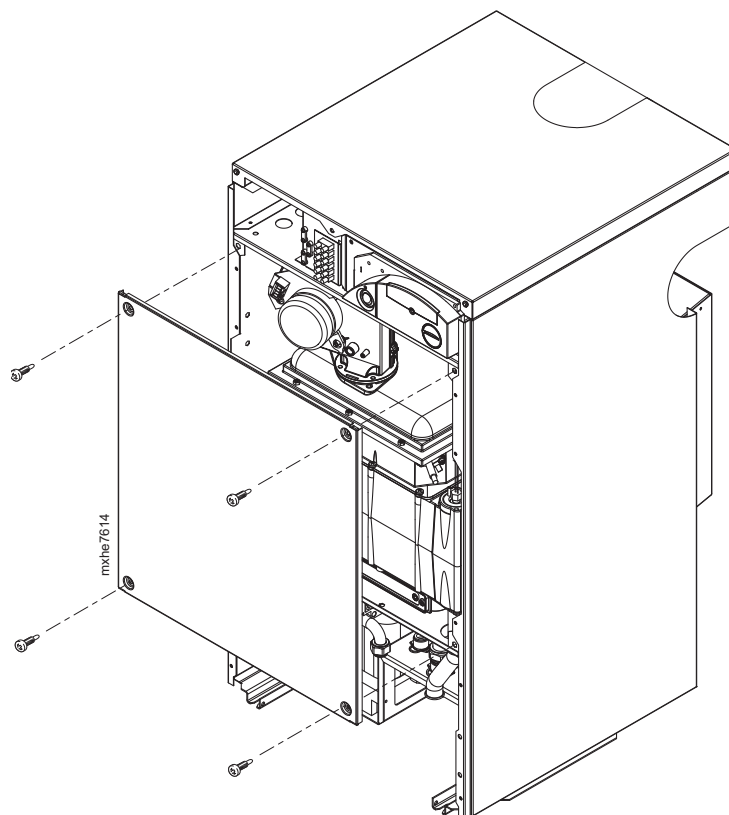

## SERVICING

### 69 CONDENSATE 'S' TRAP REPLACEMENT & CONDENSATE PUMP (IF FITTED)

1. Refer to Frame 51.
2. Remove the boiler front panels. Refer to Frame 44.
3. Condensate pump removal (if fitted):
  - a. Disconnect the outlet pipe rubber connecting joint taking care to capture any liquid held in the pipe.
  - b. Lift the inlet pipe to clear the pump.
  - c. Remove the pump wiring cover.
  - d. Remove the 5 wires from the terminal strip.
  - e. Lift the condensate pump from the two screw fixings.
  - f. Pull the pump forward and remove the wiring through the top grommet.

Outlet pipe  
Inlet pipe  
from 'S' trap

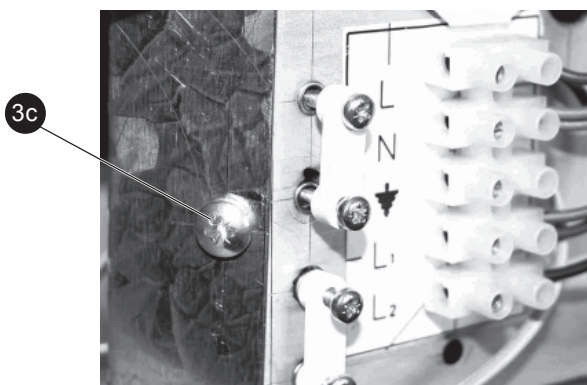
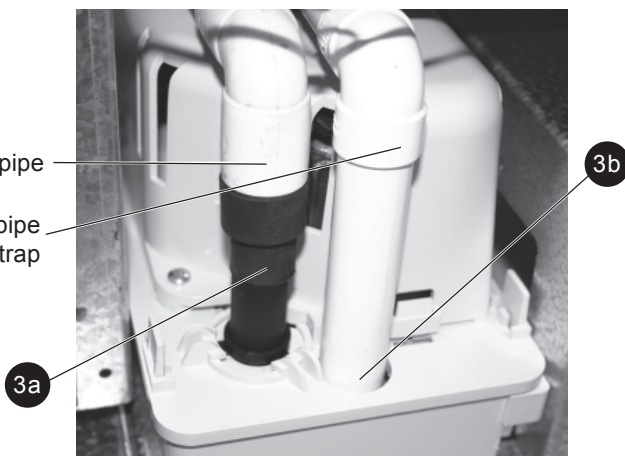

4. Undo the plastic union nut on the condensate 'S' trap outlet and disconnect the flexible hose.
5. Remove the screw retaining the 'S' trap bracket and remove the bracket.
6. Loosen the top nut on the 'S' trap then pull the trap down and forward to remove.
7. Reassemble in reverse order, ensuring the condensate pump is correctly replaced.
8. Check operation of the boiler. Refer to Frame 51.

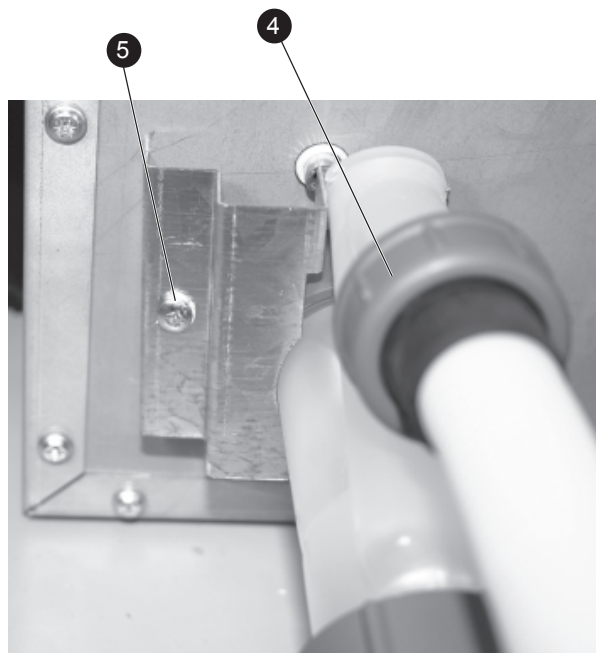

## FAULT FINDING

### 70 FAULT FINDING CHART MAIN MENU

In order to assist fault finding the boiler has an LED diagnostic display. The key to the display codes is as follows:

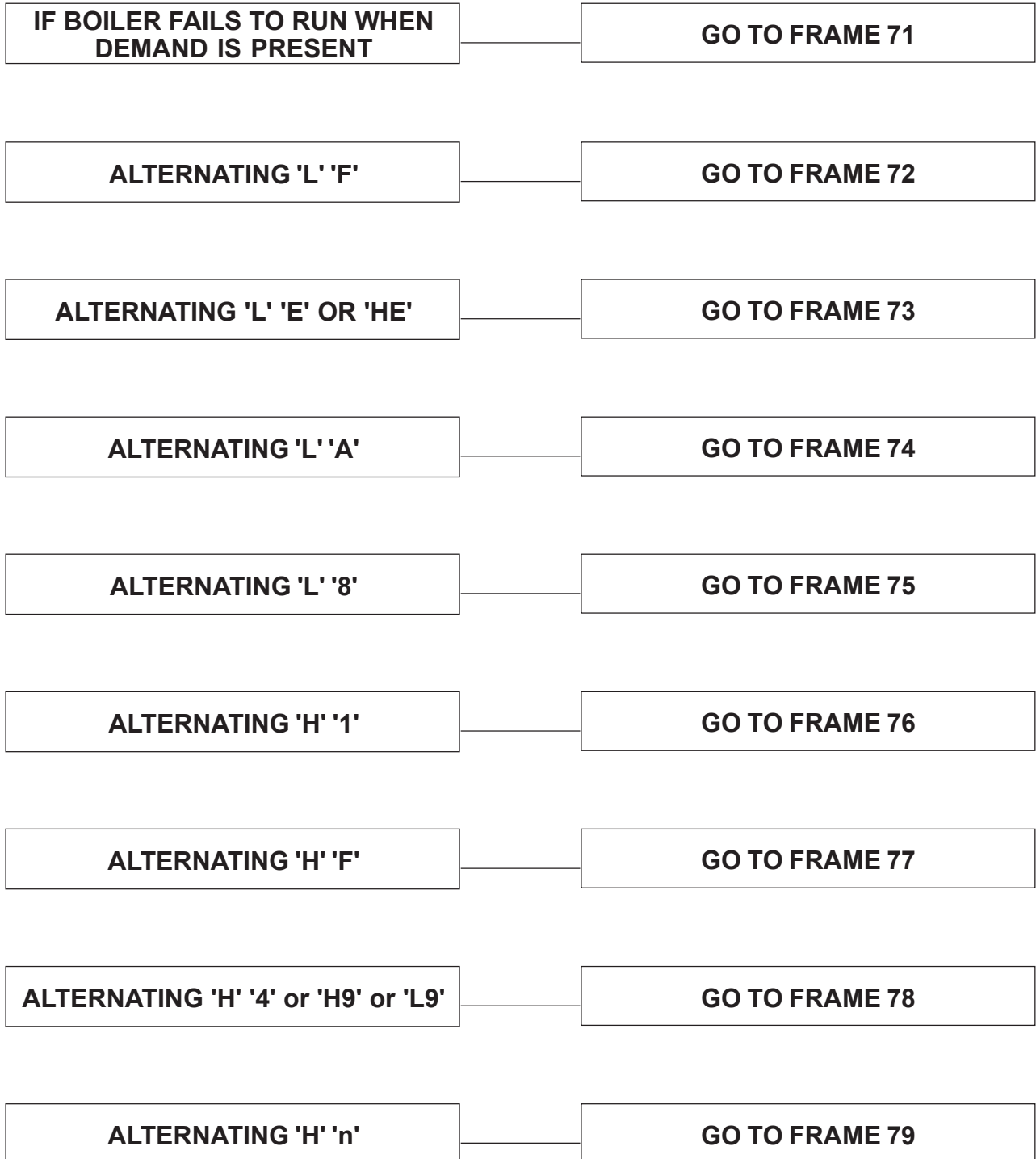

# FAULT FINDING

## 71 CONDENSATE PUMP FAILURE

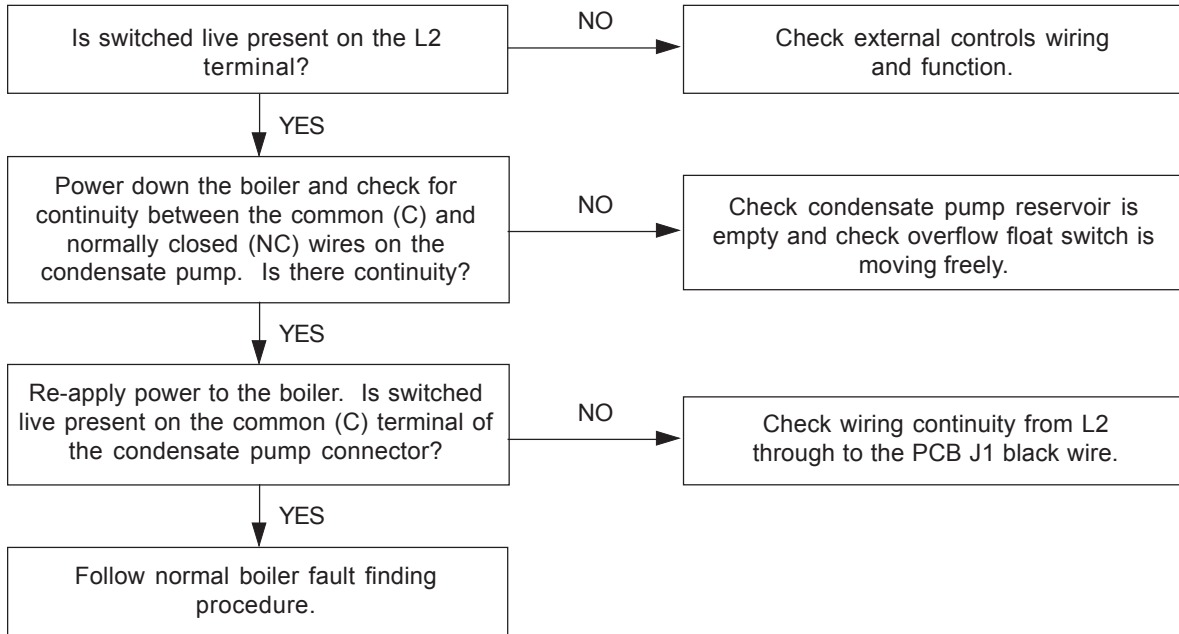

## 72 L.....F..... (FLAME ERROR)

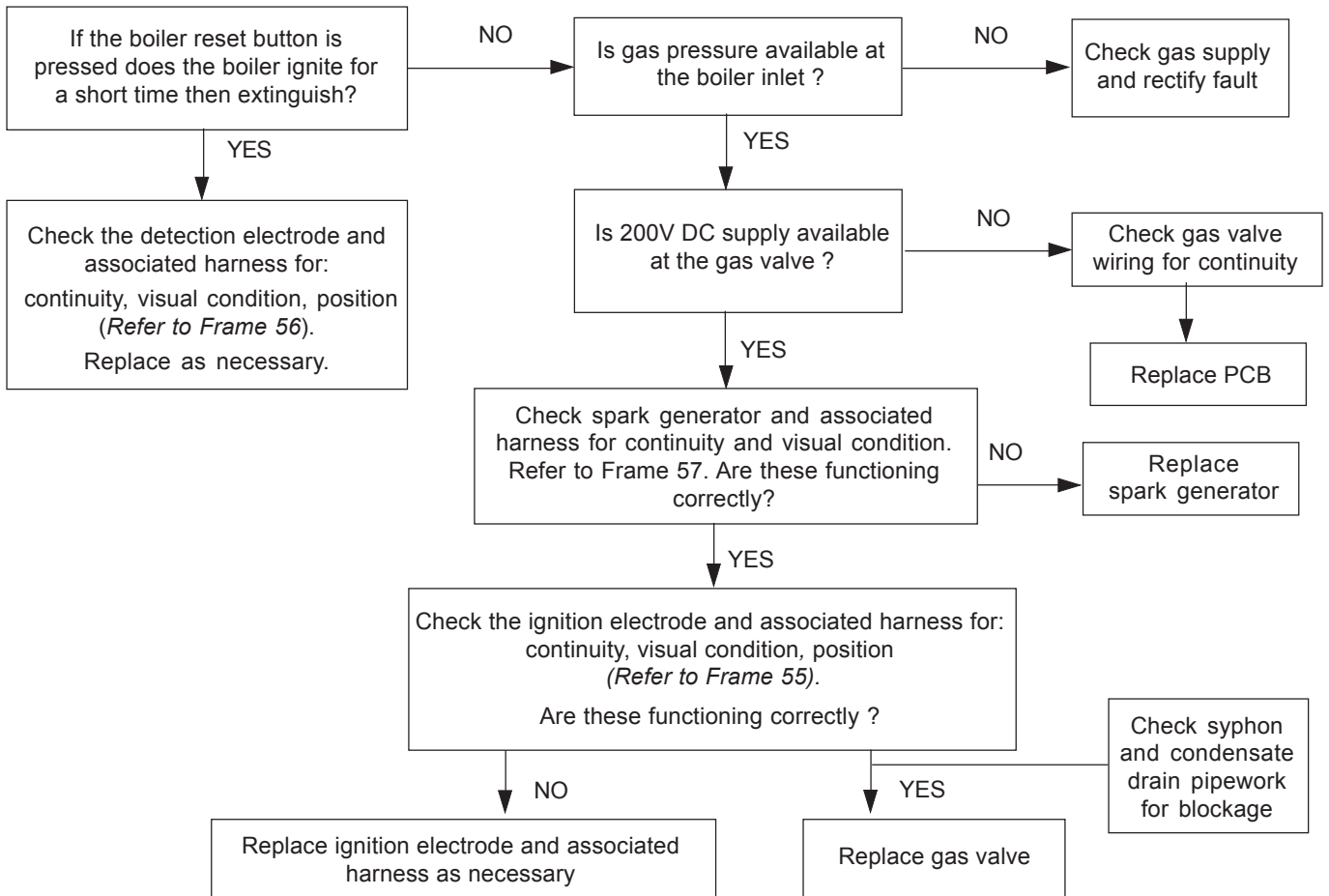

**Note.** Due to the wave form of the rectified voltage the reading will vary, depending on the type of meter used to measure the value (some may measure the possible peak voltage of 339V). In general terms, a reading greater than 150V indicates that the correct voltage is supplied to the gas valve. As an alternative to a multimeter a mains checking device may be used. E.g. an electrical screwdriver or a mains tester.

# FAULT FINDING

## 73 L.....E..... or H.....E..... (BOARD ERROR)

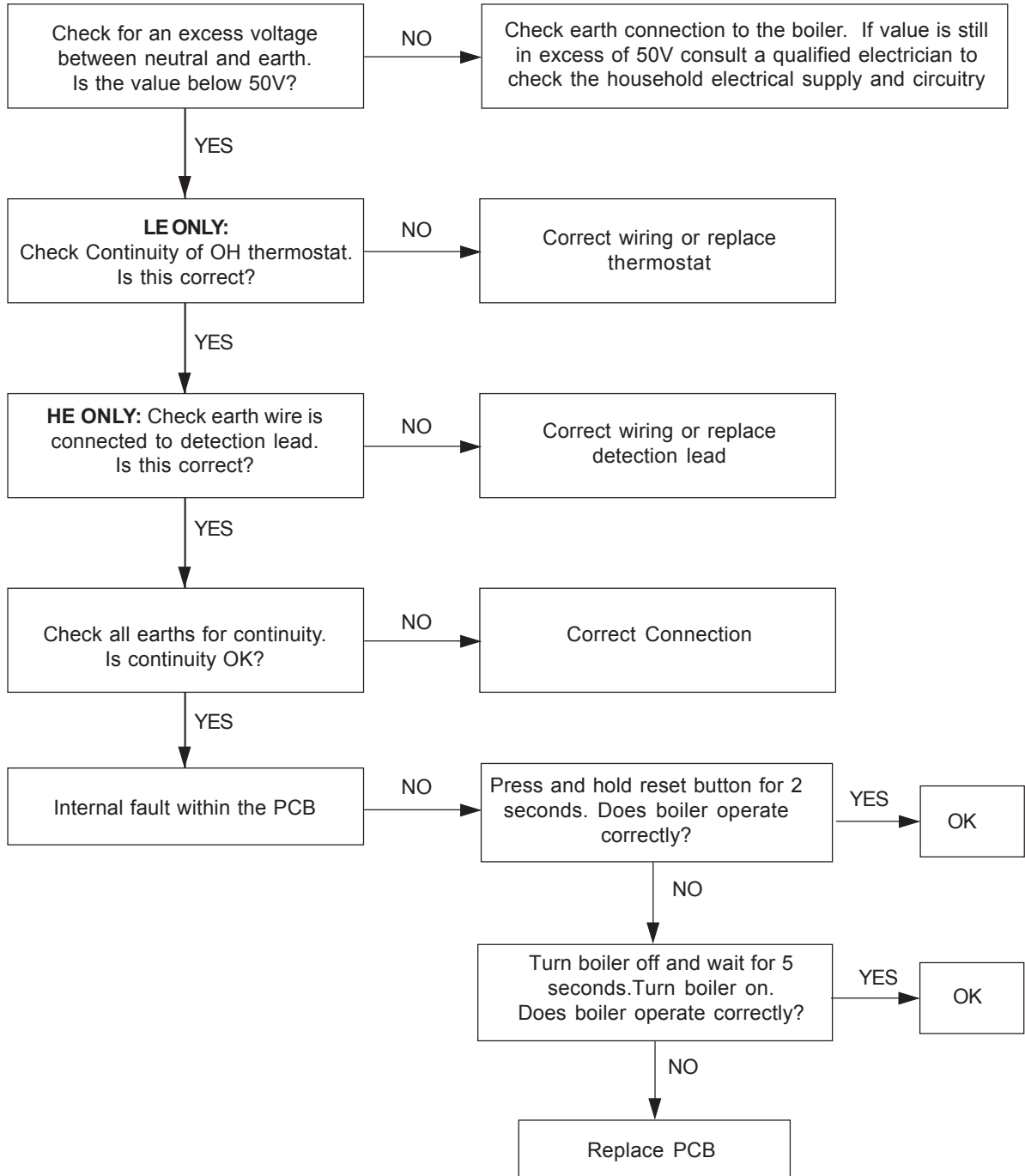

## FAULT FINDING

### 74 L.....A..... (OVERHEAT ERROR)

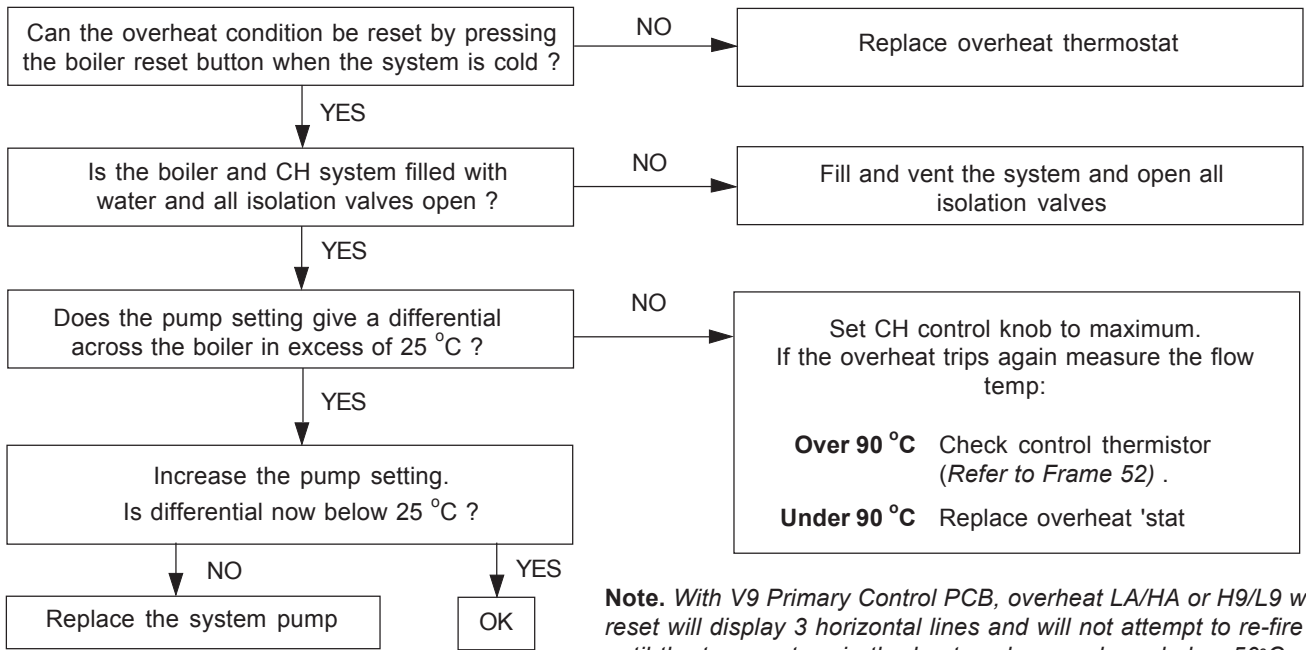

### 75 L....8..... (FAN ERROR)

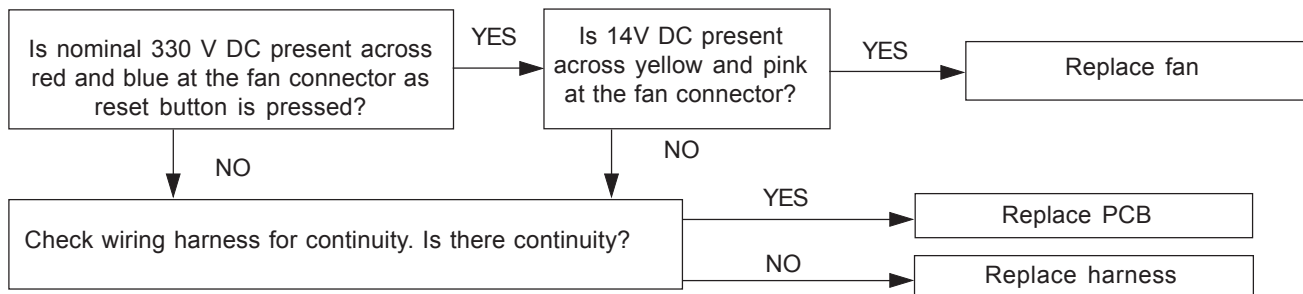

### 76 H.....1..... (FLOW THERMISTOR ERROR)

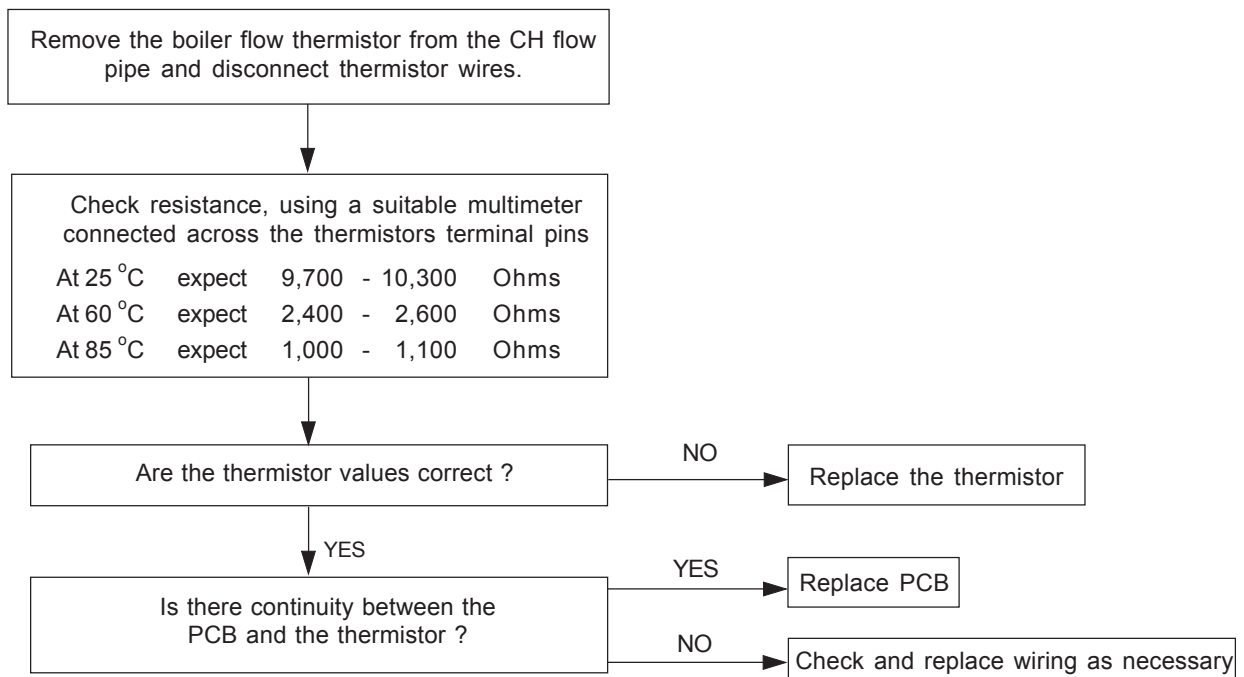



## FAULT FINDING

### 77 H.....F..... (FLAME DETECTION - SHORT CIRCUIT ERROR)

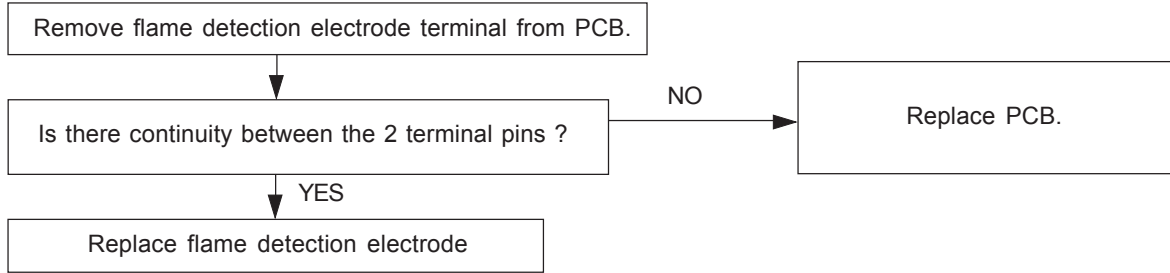

### 78 H.....4..... (DRY FIRE THERMISTOR ERROR)

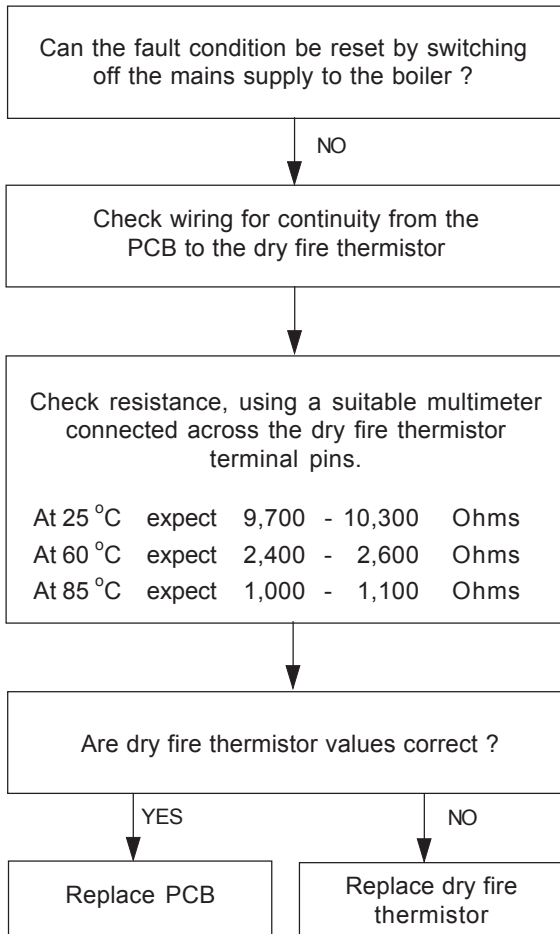

### H9/L9 (FLUE GAS OVERHEAT)

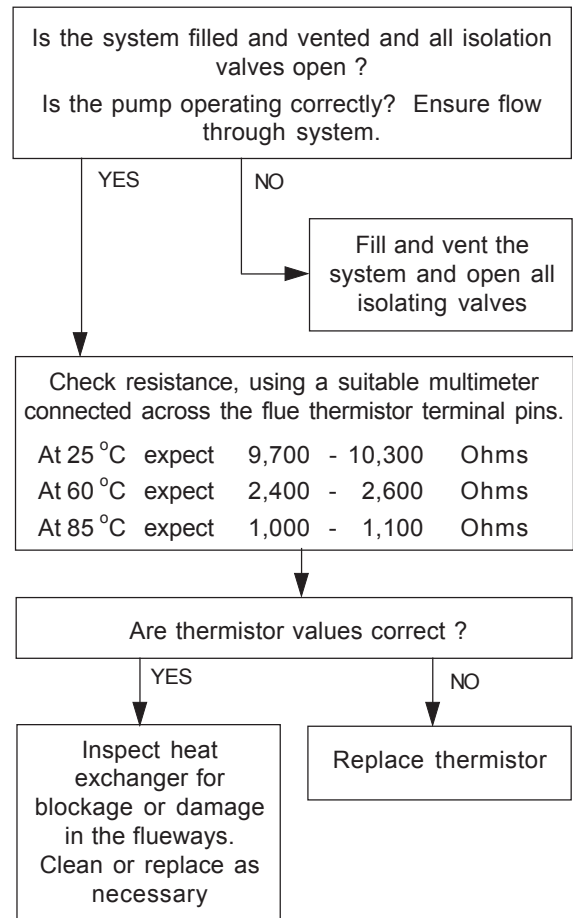

**Note.** With V9 Primary Control PCB, overheat LA/HA or H9/L9 when reset will display 3 horizontal lines and will not attempt to re-fire until the temperature in the heat exchanger drops below 50°C.

### 79 H.....n..... (PHASE REVERSAL ERROR)

Check wiring to the boiler for reversed live and neutral

## GENERAL

The following are parts commonly required due to damage or expendability. Their failure or absence is likely to affect safety or performance of this appliance.

The list is extracted from the British Gas List of Parts, which contains all available spare parts.

The full list is held by British Gas Services, **Ideal Stelrad Group** distributors and merchants.

When ordering spares please quote:

1. Boiler Model
2. Appliance G.C. Number
3. Description
4. Quantity
5. Product Number

When replacing any part on this appliance use only spare parts that you can be assured conform to the safety and performance specification that we require. Do not use reconditioned or copy parts that have not been clearly authorised by Ideal Boilers Limited.

Key No.	GC Part No.	Description	Qty.	Product No.	
1	H28-975	Front casing panel	1	174 074	
2	H28-976	Sealing panel	1	174 075	
3	H28-977	Top casing panel	1	174 076	
4	H28-979	LH casing side panel	1	174 077	
5	H28-981	RH casing side panel	1	174 078	
6	H28-982	Lower front panel	1	174 079	
14	E67-489	Burner assembly	HE15, HE18, HE24	1	170 905
	H29-002		HE30, HE36	1	174 080
15	H07-660	Combustion chamber insulation kit	HE15, HE18, HE24	1	173 520
17	E67-492	Injector & housing		1	170 908
19	E85-097	Fan assembly	HE15, HE18, HE24	1	172 625
	H07-771		HE30, HE36	1	173 525
22	H29-012	Gas valve assembly		1	174 081
25	H29-018	Dry fire thermistor		1	174 087
26	H29-019	Control thermistor		1	174 088
27	H29-020	Overheat Thermostat		1	174 089
28	H07-664	Ignition electrode		1	173 528
29	H07-665	Flame detection electrode		1	173 529
34	H29-029	Condensate 'S' trap		1	174 090
36	H29-031	Condensate 'S' trap hose		1	174 091
37	H29-032	User Control		1	174 152
38	H29-034	PCB primary control		1	174 486
39	E67-519	Fuse PCB (3.15A L250V)		1	170 931
41	H07-777	Main switch c/w harness		1	173 537
42	H29-038	Spark Generator	HE15, HE18, HE24	1	174 094
	H29-040		HE30, HE36	1	174 095
45	H29-045	Gasket kit (servicing)	HE15, HE18, HE24	1	174 169
	H29-047		HE30, HE36	1	174 096
46	H29-048	Burner gasket	HE15 HE18, HE24	1	174 092
	H29-050		HE30, HE36	1	174 093
54	E78-200	Burner earth pin (ionisation probe)	HE15, HE18, H24	2	171 845
	H29-062		HE30, HE36	1	174 086
68	H07-790	Ignition lead		1	173 510
69	H07-792	Detection lead	HE15, HE18, HE24	1	173 512
			HE30, HE36	1	174 083

# GENERAL

## 80 SHORT LIST

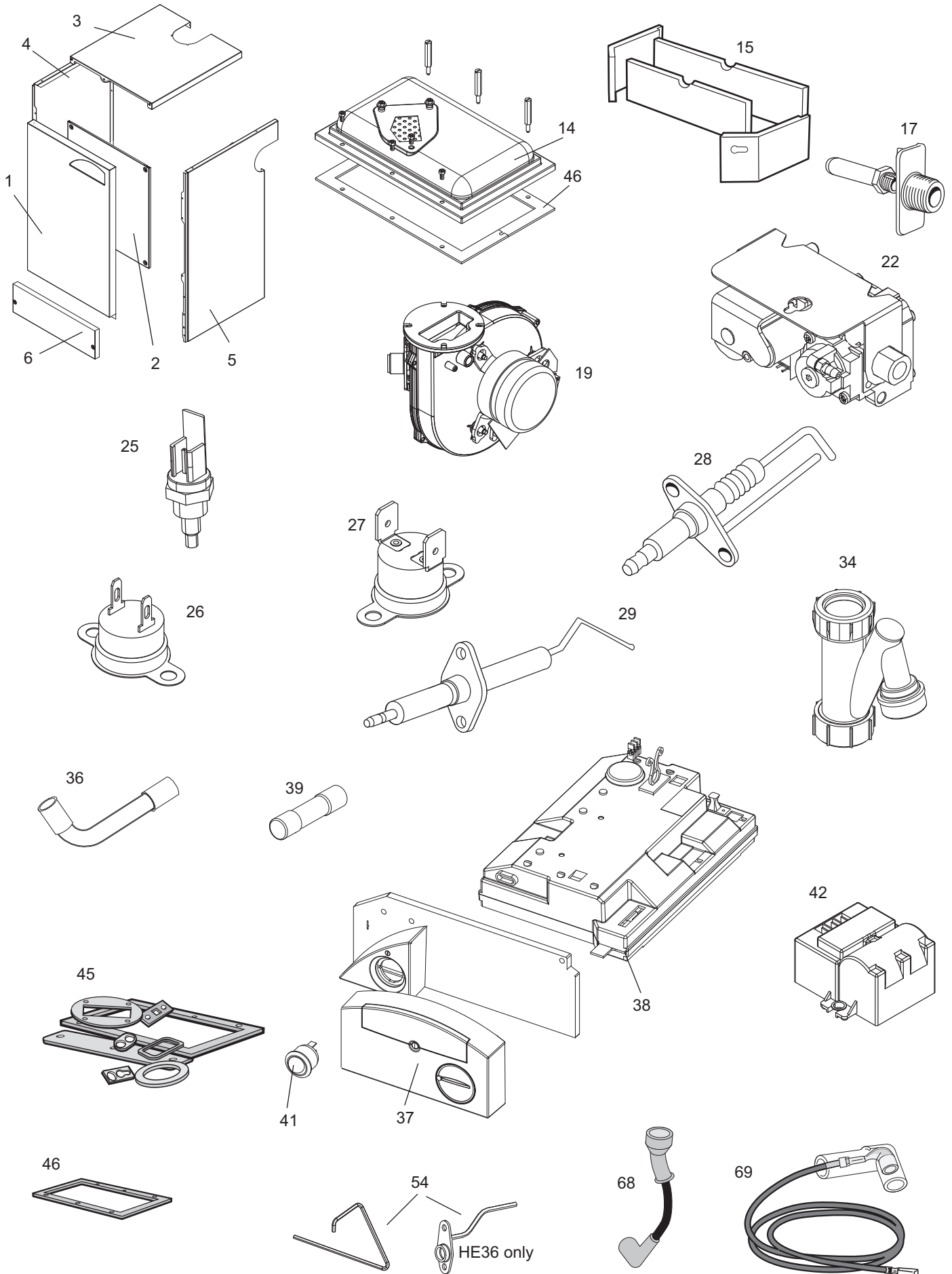

mxhe7618

## NOTES

# INSTALLER NOTIFICATION GUIDELINES

## IT IS A REQUIREMENT OF CORGI MEMBERSHIP TO REGISTER EVERY GAS APPLIANCE

In addition a change to Building Regulations (England and Wales) requires the installer to notify when installing a heating appliance, as from 1st April 2005.

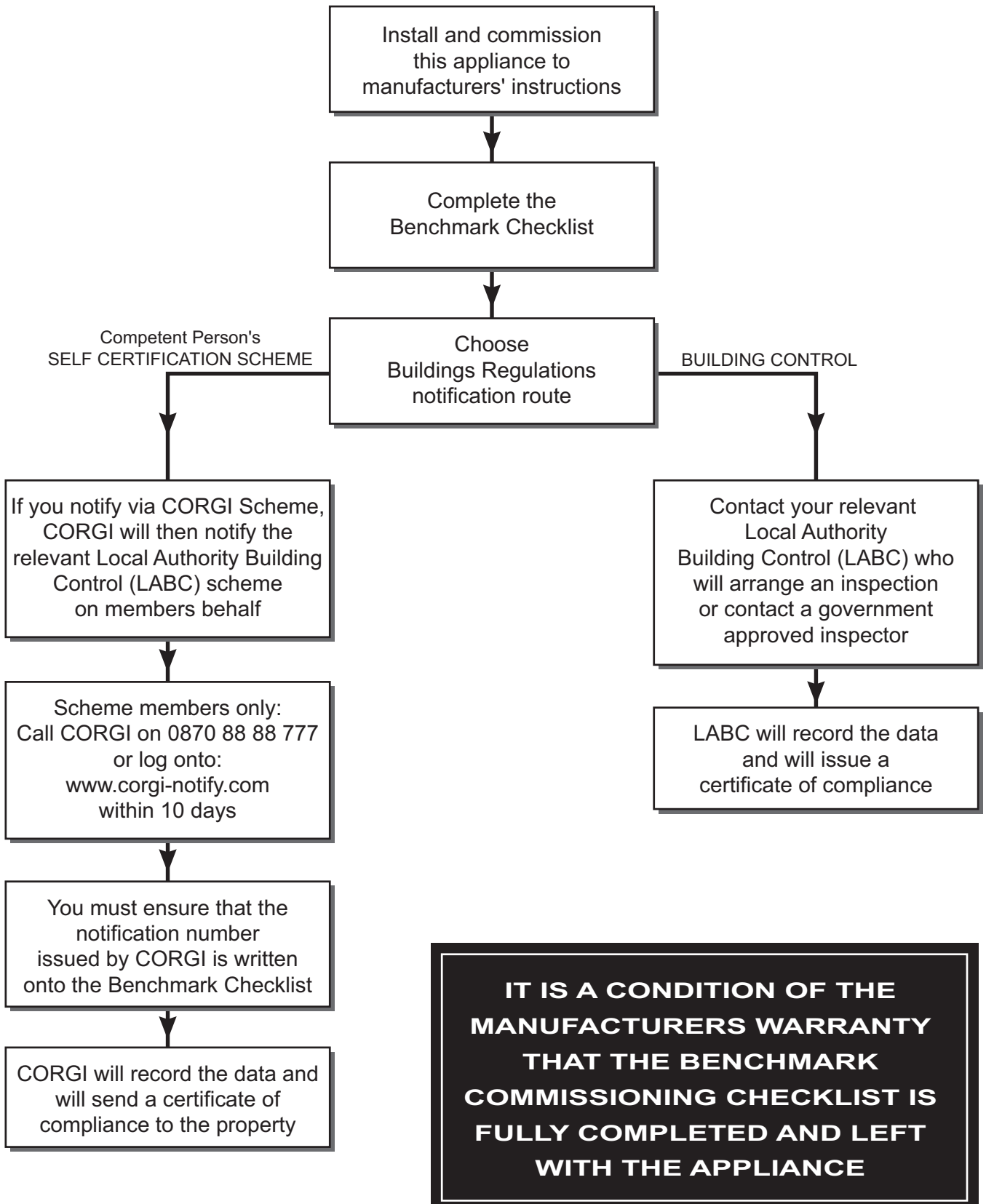



BENCHMARK No. | | | | | | | |

# GAS BOILER COMMISSIONING CHECKLIST

BOILER SERIAL No. \_\_\_\_\_ NOTIFICATION No. \_\_\_\_\_

**CONTROLS** To comply with the Building Regulations, each section must have a tick in one or other of the boxes

TIME & TEMPERATURE CONTROL TO HEATING	ROOM T/STAT & PROGRAMMER/TIMER <input type="checkbox"/>	PROGRAMMABLE ROOMSTAT <input type="checkbox"/>
TIME & TEMPERATURE CONTROL TO HOT WATER	CYLINDER T/STAT & PROGRAMMER/TIMER <input type="checkbox"/>	COMBI BOILER <input type="checkbox"/>
HEATING ZONE VALVES	FITTED <input type="checkbox"/>	NOT REQUIRED <input type="checkbox"/>
HOT WATER ZONE VALVES	FITTED <input type="checkbox"/>	NOT REQUIRED <input type="checkbox"/>
THERMOSTATIC RADIATOR VALVES	FITTED <input type="checkbox"/>	
AUTOMATIC BYPASS TO SYSTEM	FITTED <input type="checkbox"/>	NOT REQUIRED <input type="checkbox"/>

## FOR ALL BOILERS CONFIRM THE FOLLOWING

THE SYSTEM HAS BEEN FLUSHED IN ACCORDANCE WITH THE BOILER MANUFACTURER'S INSTRUCTIONS?

THE SYSTEM CLEANER USED \_\_\_\_\_

THE INHIBITOR USED \_\_\_\_\_

## FOR THE CENTRAL HEATING MODE, MEASURE & RECORD

GAS RATE \_\_\_\_\_ m<sup>3</sup>/hr \_\_\_\_\_ ft<sup>3</sup>/hr

BURNER OPERATING PRESSURE (IF APPLICABLE)  N/A \_\_\_\_\_ mbar

CENTRAL HEATING FLOW TEMPERATURE \_\_\_\_\_ °C

CENTRAL HEATING RETURN TEMPERATURE \_\_\_\_\_ °C

## FOR COMBINATION BOILERS ONLY

HAS A WATER SCALE REDUCER BEEN FITTED? YES  NO

WHAT TYPE OF SCALE REDUCER HAS BEEN FITTED? \_\_\_\_\_

## FOR THE DOMESTIC HOT WATER MODE, MEASURE & RECORD

GAS RATE \_\_\_\_\_ m<sup>3</sup>/hr \_\_\_\_\_ ft<sup>3</sup>/hr

MAXIMUM BURNER OPERATING PRESSURE (IF APPLICABLE)  N/A \_\_\_\_\_ mbar

COLD WATER INLET TEMPERATURE \_\_\_\_\_ °C

HOT WATER OUTLET TEMPERATURE \_\_\_\_\_ °C

WATER FLOW RATE \_\_\_\_\_ lts/min

## FOR CONDENSING BOILERS ONLY CONFIRM THE FOLLOWING

THE CONDENSATE DRAIN HAS BEEN INSTALLED IN ACCORDANCE WITH THE MANUFACTURER'S INSTRUCTIONS? YES

## FOR ALL INSTALLATIONS CONFIRM THE FOLLOWING

THE HEATING AND HOT WATER SYSTEM COMPLIES WITH CURRENT BUILDING REGULATIONS

THE APPLIANCE AND ASSOCIATED EQUIPMENT HAS BEEN INSTALLED AND COMMISSIONED IN ACCORDANCE WITH THE MANUFACTURER'S INSTRUCTIONS

IF REQUIRED BY THE MANUFACTURER, HAVE YOU RECORDED A CO/CO<sub>2</sub> RATIO READING? N/A  YES \_\_\_\_\_ CO/CO<sub>2</sub> RATIO

THE OPERATION OF THE APPLIANCE AND SYSTEM CONTROLS HAVE BEEN DEMONSTRATED TO THE CUSTOMER

THE MANUFACTURER'S LITERATURE HAS BEEN LEFT WITH THE CUSTOMER

COMMISSIONING ENG'S NAME PRINT \_\_\_\_\_ CORGI ID No. \_\_\_\_\_

SIGN \_\_\_\_\_ DATE \_\_\_\_\_



# SERVICE INTERVAL RECORD

It is recommended that your heating system is serviced regularly and that you complete the appropriate Service Interval Record Below.

**Service Provider.** Before completing the appropriate Service Interval Record below, please ensure you have carried out the service as described in the boiler manufacturer's instructions. Always use the manufacturer's specified spare part when replacing all controls

**SERVICE 1** DATE \_\_\_\_\_  
ENGINEER NAME \_\_\_\_\_  
COMPANY NAME \_\_\_\_\_  
TEL No. \_\_\_\_\_  
CORGI ID CARD SERIAL No. \_\_\_\_\_  
COMMENTS \_\_\_\_\_  
SIGNATURE \_\_\_\_\_

**SERVICE 2** DATE \_\_\_\_\_  
ENGINEER NAME \_\_\_\_\_  
COMPANY NAME \_\_\_\_\_  
TEL No. \_\_\_\_\_  
CORGI ID CARD SERIAL No. \_\_\_\_\_  
COMMENTS \_\_\_\_\_  
SIGNATURE \_\_\_\_\_

**SERVICE 3** DATE \_\_\_\_\_  
ENGINEER NAME \_\_\_\_\_  
COMPANY NAME \_\_\_\_\_  
TEL No. \_\_\_\_\_  
CORGI ID CARD SERIAL No. \_\_\_\_\_  
COMMENTS \_\_\_\_\_  
SIGNATURE \_\_\_\_\_

**SERVICE 4** DATE \_\_\_\_\_  
ENGINEER NAME \_\_\_\_\_  
COMPANY NAME \_\_\_\_\_  
TEL No. \_\_\_\_\_  
CORGI ID CARD SERIAL No. \_\_\_\_\_  
COMMENTS \_\_\_\_\_  
SIGNATURE \_\_\_\_\_

**SERVICE 5** DATE \_\_\_\_\_  
ENGINEER NAME \_\_\_\_\_  
COMPANY NAME \_\_\_\_\_  
TEL No. \_\_\_\_\_  
CORGI ID CARD SERIAL No. \_\_\_\_\_  
COMMENTS \_\_\_\_\_  
SIGNATURE \_\_\_\_\_

**SERVICE 6** DATE \_\_\_\_\_  
ENGINEER NAME \_\_\_\_\_  
COMPANY NAME \_\_\_\_\_  
TEL No. \_\_\_\_\_  
CORGI ID CARD SERIAL No. \_\_\_\_\_  
COMMENTS \_\_\_\_\_  
SIGNATURE \_\_\_\_\_

**SERVICE 7** DATE \_\_\_\_\_  
ENGINEER NAME \_\_\_\_\_  
COMPANY NAME \_\_\_\_\_  
TEL No. \_\_\_\_\_  
CORGI ID CARD SERIAL No. \_\_\_\_\_  
COMMENTS \_\_\_\_\_  
SIGNATURE \_\_\_\_\_

**SERVICE 8** DATE \_\_\_\_\_  
ENGINEER NAME \_\_\_\_\_  
COMPANY NAME \_\_\_\_\_  
TEL No. \_\_\_\_\_  
CORGI ID CARD SERIAL No. \_\_\_\_\_  
COMMENTS \_\_\_\_\_  
SIGNATURE \_\_\_\_\_

**SERVICE 9** DATE \_\_\_\_\_  
ENGINEER NAME \_\_\_\_\_  
COMPANY NAME \_\_\_\_\_  
TEL No. \_\_\_\_\_  
CORGI ID CARD SERIAL No. \_\_\_\_\_  
COMMENTS \_\_\_\_\_  
SIGNATURE \_\_\_\_\_

**SERVICE 10** DATE \_\_\_\_\_  
ENGINEER NAME \_\_\_\_\_  
COMPANY NAME \_\_\_\_\_  
TEL No. \_\_\_\_\_  
CORGI ID CARD SERIAL No. \_\_\_\_\_  
COMMENTS \_\_\_\_\_  
SIGNATURE \_\_\_\_\_



*The code of practice for the installation,  
commissioning & servicing of central heating systems*

### Technical Training

The Ideal Boilers Technical Training Centre offers a series of first class training courses for domestic, commercial and industrial heating installers, engineers and system specifiers.

For details of courses please ring: ..... 01482 498 432



CERTIFIED PRODUCT  
Manufactured under a BS EN ISO 9001:  
2000 Quality System accepted by BSI

**Ideal Boilers**, P.O. Box 103, National Ave, Kingston upon Hull, HU5 4JN. Telephone: 01482 492 251 Fax: 01482 448 858. Registration No. London 322 137.

**Ideal Stelrad Group** pursues a policy of continuing improvement in the design and performance of its products. The right is therefore reserved to vary specification without notice.



**i Ideal** BOILERS  
The High Efficiency Pioneers



Ideal Stelrad Group

***Ideal Installer/Technical Helpline: 01482 498 663***  
***www.idealboilers.com***